

Laboratory Equipment

velp[®]

Driven by curiosity

LE

Our Manifesto

Science is driven by a curiosity about the natural world and the human desire to understand how things work.

Every day a sense of wonder motivates scientists to explore the unknown and ask fundamental questions about the world around us.

We at Velp embrace this spirit, fostering openmindedness and creativity.

We blend Italian craftsmanship with state-of-the art technology to deliver exceptionally userfriendly and reliable laboratory equipment and analytical instruments.

Renowned for our clean, minimalist design, we strive to simplify the scientific routines of those committed to enhancing quality of life and addressing critical global challenges.

We'll keep pushing the limits of innovation, always evolving in everything we do — just as you do.

Product Overview

Velp Ermes

Smart Lab Cloud platform	8
Velp Ermes Subscriptions	8

Magnetic Stirrers

MSL 50 Digital	9
MSL 25 Digital	9
MSL 8 Digital	10
MSL 8	10
MST Digital	11
MST	11
MICROSTIRRER	12
ESP	12
MULTISTIRRER 15 Digital	13
MULTISTIRRER 6 Digital	13
MULTISTIRRER 15	14
MULTISTIRRER 6	14
AMI	15
AMI 4	15

Heating Magnetic Stirrers

AREX 5 Advance	17
AREX 5 Digital	18
AREX 5	19
ARE 5	20
AM 4 Digital	21
AM 4	22
AREC 4 Digital	25
AREC 4	26
AREC 7 Advance	27
AREC 7 Digital	28
AREC 7	29
AREC 10 Advance	31
AREC 10 Digital	32
MULTI-HS 15 Digital	34
MULTI-HS 6 Digital	35
VTF	36

Heating Plates

RC 5	37
RC 2	37
REC 7 Digital	38
REC 10 Digital	38

Overhead Stirrer

OHS 200 Advance	40
OHS 100 Advance	40
OHS 60 Advance	41
OHS 200 Digital	41
OHS 100 Digital	42
OHS 60 Digital	42
OHS 40 Digital	43
OHS 20 Digital	43
DLH	44
DLS	44
PW	45
LH	45
LS	46
ES	46
CONTROLLER Advance	49
CONTROLLER Digital	49

Vortex Mixers

Wizard IR	50
Classic	50
TX4	51
ZX4	51
ZX3	52
RX3	52
ROTAX 6.8 Overhead Mixer	53
MULTI-TX5	54

Dispersers

OV 725 Digital	55
OV 625 Digital	56

COD Thermoreactors

ECO 16	58
ECO 6	58
ECO 25	59
ECO 8	59

BOD and Respirometers

RESPIROMETRIC Sensor System 6 BOD	61
RESPIROMETRIC Sensor System 6 Maxi BMP	61
RESPIROMETRIC Sensor System for Soils Analysis	62
RESPIROMETRIC Sensor System 6 for Plastic	62
BOD Sensor	63
BOD Sensor System 6	63
BOD Sensor System 10	64

Cooled Incubators

FOC 200IL Connect	65
FOC 200I Connect	65
FOC 200E Connect	66
FOC 120I Connect	66
FOC 120E Connect	67
FTC 120	67

Flocculators

JLT 6	69
JLT 4	69
FC6S	70
FC4S	70
FP4	71

Other Solutions

OCB Open Circulating Baths	72
SP 311 Peristaltic Pumps	72
TB1 Turbidimeter	73



Temp 49.8 °C

50 Set

2-3

00:05:25

AREC 10 Advance Heating Magnetic Stirrers

veip®

Velp Ermes

Smart Lab Cloud Platform

Velp Ermes creates a connected ecosystem of devices, people and data that transmit information between each other cutting down distances and expanding your scientific potential.



Monitor and Control Your Instruments

Monitor and manage multiple instruments 24/7 from any smart device. Control your analysis and the instruments' working conditions in real time, and receive immediate notifications and alerts.



Remote Service Support

Velp Ermes can help you get the most out of your instruments by providing direct contact with Velp specialists and official partners.



Your Instruments are Always Updated

Your instrument can be connected via secure Wi-Fi or cable, and the software can be updated immediately at no cost.



Safely Manage your Data

Collect and store your data with maximum encryption and cybersecurity standards. Generate and share your analysis reports in multiple formats.

Velp Ermes Subscriptions

Set up your account and connect your instruments to access all Velp Ermes services and features free of charge for the first three months. After the trial period, you can choose to extend your subscription with an Ermes Card, available for 1 or 3 years. Each card allows you to connect up to 10 instruments within your organization.



FREE TRIAL
3 Months per instrument

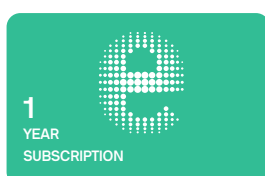

1 YEAR / 10 INSTRUMENTS
Code E00010012

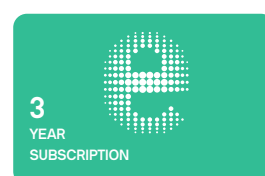

3 YEARS / 10 INSTRUMENTS
Code E00010036

Magnetic Stirrers

MSL 50 Digital

High volume magnetic stirrer with digital display to accurately set the working conditions. Programmable operations with the integrated timer and auto-reverse. Main applications of MSL 50 Digital are high volumes preparations, cell cultures and tissue cultures, buffer solution preparations.

Precise and Programmable

SpeedServo™ technology maintains constant speed. Unattended stirring from 1 minute to 99 h 59 minutes.

Robust and Versatile

The brushless motor provides continuous operation for high volumes at any speed. Robust stainless steel top for easy visualization of color changes and particles.

- Volume (H₂O) 50 L
- Stirring speed from 20 to 1000 rpm
- Timer & Auto-reverse



MSL 50 Digital



100÷240 V / 50-60 Hz

F203A0512

MSL 25 Digital

High volume magnetic stirrer with digital display to accurately set the working conditions. Programmable operations with the integrated timer and auto-reverse. Main applications of MSL 25 Digital are high volumes preparations, cell cultures and tissue cultures, buffer solution preparations.

Precise and Programmable

SpeedServo™ technology maintains constant speed. Unattended stirring from 1 minute to 99 h 59 minutes.

Robust and Versatile

The brushless motor provides continuous operation for high volumes at any speed. Robust stainless steel top for easy visualization of color changes and particles.

- Volume (H₂O) 25 L
- Stirring speed from 40 to 1500 rpm
- Timer & Auto-reverse



MSL 25 Digital



100÷240 V / 50-60 Hz

F203A0511

MSL 8 Digital

High volume magnetic stirrer with digital display to accurately set the working conditions. Programmable operations with the integrated timer and auto-reverse. Main applications of MSL 8 Digital are high volumes preparations, cell cultures and tissue cultures, buffer solution preparations.

Precise and Programmable

SpeedServo™ technology maintains constant speed. Unattended stirring from 1 minute to 99 h 59 minutes.

Robust and Versatile

The brushless motor provides continuous operation for high volumes at any speed. Robust stainless steel top for easy visualization of color changes and particles.

- Volume (H₂O) 8 L
- Stirring speed from 40 to 1500 rpm
- Timer & Auto-reverse
- Safety Lock



MSL 8 Digital



100±240 V / 50-60 Hz

F203A0510

MSL 8

Magnetic stirrer guaranteeing continuous operations at any speed ensuring safety and resistance to chemical agents. MSL 8 has a gentle start in order to protect the sample. The control panel is protected from liquid spills.

Precise and Programmable

SpeedServo™ technology maintains constant speed.

Robust and Versatile

The brushless motor provides continuous operation for high volumes at any speed. Robust stainless steel top for easy visualization of color changes and particles.

- Volume (H₂O) 8 L
- Stirring speed from 40 to 1500 rpm



MSL 8



100±240 V / 50-60 Hz

F203A0513

MST Digital

Compact magnetic stirrer with digital display with accurate speed setting, timer and auto-reverse. The white surface is designed to facilitate the visualization of particles and color change. MST Digital allows continuous operation and remains cold even after days of continuous use. Main applications in microbiology, biochemistry and chemistry.

Precise and Programmable

SpeedServo™ technology maintains constant speed. Unattended stirring from 1 to 900 minutes.

Powerful

Equipped with a powerful brushless motor.

- Volume (H₂O) 5 L
- Stirring speed up to 1500 rpm
- Timer & Auto-reverse
- Safety Lock



MST Digital



100÷240 V / 50-60 Hz

F203A0450

MST

Powerful and compact magnetic stirrer with a low profile. The white surface is designed to facilitate the visualization of particles and color change. MST allows continuous operation and remains cold even after days of continuous use. Main applications in microbiology, biochemistry and chemistry.

Resistant

The technopolymer structure ensures maximum resistance to chemicals.

- Volume (H₂O) 5 L
- Stirring speed up to 1100 rpm



MST



100÷240 V / 50-60 Hz

F203A0440

MICROSTIRRER

Compact and light weight magnetic stirrer with metal structure for visualization of particles and color changes. Specially designed for microtitrations.

Reliable

It remains cold, even after days of continuous use and guarantees excellent speed control, even at low speed.

- Volume (H₂O) 5 L
- Stirring speed up to 1100 rpm



MICROSTIRRER



100±240 V / 50-60 Hz

F203A0161

ESP

Flat and light weight magnetic stirrer with no moving mechanical components: it is therefore maintenance-free. The clear surface is ideal for visualization of particles and color changes.

Resistant

The control panel is protected from liquid spills with run-off groove and the technopolymer casing resists chemicals.

- Volume (H₂O) 5 L
- Stirring speed up to 1100 rpm



ESP



100±240 V / 50-60 Hz

F206A0179

MULTISTIRRER 15 Digital

Multi position magnetic stirrer with stainless steel top for the simultaneous stirring of 15 positions. A bright digital display to accurately set the stirring speed, timer, and auto-reverse. Ideal for chemistry, microbiology, biochemistry applications.

Precise and Programmable

SpeedServo™ technology maintains constant speed. Unattended stirring from 1 minute to 99 h : 59 minutes.

Resistant

Stainless steel top plate. The control panel is shielded from liquid spills.

- Volume (H₂O) 250 ml (x15)
- Stirring speed from 80 to 1500 rpm
- Timer & Auto-reverse
- Safety Lock



MULTISTIRRER 15 Digital



100±240 V / 50-60 Hz

F203A0180

MULTISTIRRER 6 Digital

Multi position magnetic stirrer with stainless steel top for the simultaneous stirring of 6 positions. A bright digital display to accurately set the stirring speed, timer, and auto-reverse. Ideal for chemistry, microbiology, biochemistry applications.

Precise and Programmable

SpeedServo™ technology maintains constant speed. Unattended stirring from 1 minute to 99 h : 59 minutes.

Resistant

Stainless steel top plate. The control panel is shielded from liquid spills.

- Volume (H₂O) 400 ml (x6)
- Stirring speed from 80 to 1500 rpm
- Timer & Auto-reverse
- Safety Lock



MULTISTIRRER 6 Digital



100±240 V / 50-60 Hz

F203A0179

MULTISTIRRER 15

Multi position magnetic stirrer with stainless steel top for the simultaneous stirring of 15 positions. Pale surface for visualization of particles and color changes. Remains cold, even after days of continuous use. Ideal for chemistry, microbiology, biochemistry applications.

Precise

SpeedServo™ technology maintains constant speed.

Resistant

Stainless steel top plate. The control panel is shielded from liquid spills.

- Volume (H₂O) 250 ml (x15)
- Stirring speed from 80 to 1500 rpm



MULTISTIRRER 15

100±240 V / 50-60 Hz

F203A0178

MULTISTIRRER 6

Multi position magnetic stirrer with stainless steel top for the simultaneous stirring of 6 positions. Pale surface for visualization of particles and color changes. Remains cold, even after days of continuous use. Ideal for chemistry, microbiology, biochemistry applications.

Precise

SpeedServo™ technology maintains constant speed.

Resistant

Stainless steel top plate. The control panel is shielded from liquid spills.

- Volume (H₂O) 400 ml (x6)
- Stirring speed from 80 to 1500 rpm



MULTISTIRRER 6

100±240 V / 50-60 Hz

F203A0177

AMI

Illuminated magnetic stirrer particularly useful for titrations. The illuminated surface facilitates the visualization of particles and color changes. It guarantees excellent speed control (electronic), even at low speed.

Resistant

Epoxy-coated tough steel casing and stainless steel cover. The control panel is shielded from liquid spills.

Reliable

It remains cold, even after days of continuous use and is equipped with a pale surface for visualization of particles and color changes.

- Volume (H₂O) 5 L
- Stirring speed up to 1100 rpm
- LED

ILLUMINATED



AMI



100±240 V / 50-60 Hz

F204A0167

AMI 4

Illuminated multi-position magnetic stirrer particularly useful for titrations. The illuminated surface facilitates the visualization of particles and color changes. It guarantees excellent speed control (electronic), even at low speed.

Resistant

Epoxy-coated tough steel casing and stainless steel cover. The control panel is shielded from liquid spills.

Reliable

It remains cold, even after days of continuous use and is equipped with a pale surface for visualization of particles and color changes.

- Volume (H₂O) 5 L (x4)
- Stirring speed up to 1100 rpm
- LED

ILLUMINATED



AMI 4



100±240 V / 50-60 Hz

F204A0168

Accessories - Magnetic Stirrer

	MST	MST Digital	MICRO-STIRRER	ESP	MSL 8	MSL 8 Digital	MSL 25 Digital	MSL 50 Digital	AMI	AMI 4	MULTISTIRRER	MULTISTIRRER Digital
A00001057 Magnetic stir bar, Ø 6x20 mm	•	•	•						•	•	•	•
A00001056 Magnetic stir bar, Ø 6x35 mm	•	•	•		•	•			•	•	•	•
A00001061 Magnetic stir bar, Ø 9.5x60mm								•				
A00000356 Magnetic stir bar, Ø 8x40 mm				•	•	•						
A00000387 Magnetic stir bar, Ø 8x50 mm							•					
A00001055 Thermostatic bath for samples, 280x180x410 mm											•	•
10003083 Plug USA for power supply	•	•	•	•	•	•	•	•	•	•	•	•
10003084 Plug UK for power supply	•	•	•	•	•	•	•	•	•	•	•	•
10003085 Plug AU for power supply	•	•	•	•	•	•	•	•	•	•	•	•



Heating Magnetic Stirrer

AREX 5 Advance

Advanced hot plate stirrer that delivers powerful performance, precise thermoregulation, and smart connectivity. The intuitive interface with capacitive buttons and tempered glass panel enables effortless control of all parameters. Set temperature ramps, monitor viscosity, and optimize your workflow.

Elevating Laboratory Standards

Switch between multiple heating and stirring modes and choose the connectivity option: remote control via Velp Ermes Cloud Platform or local data management via ControllerSoft™ Software.

Precise Thermoregulation

Excellent temperature accuracy and reproducibility with Pt100, Pt1000 Probe and VTF.

Powerful Stirring

Brushless motor and strong magnetic coupling ensure consistent, maintenance-free stirring.

Safe and resistant

Multiple safety features, including: safety lock button, over-temperature protection, and the "hot" warning above 50°C.

- Volume (H₂O) 25 L
- Stirring speed from 30 to 1700 rpm
- Temperature from room temperature to 310 °C
- Timer & Auto-reverse
- Safety Lock
- External connection Pt 100, Pt 1000 Probes
- Ramps up to 9 temperatures, up to 9 speeds



ERMES ENABLED

Configurations - AREX 5 Advance



AREX 5 Advance



AREX 5 Advance System with Temperature Probe



AREX 5 Advance System with Temperature Probe, Rod and Clamp



AREX 5 Advance	230 V / 50-60 Hz	F20500584
AREX 5 Advance	115 V / 60 Hz	F20510584
AREX 5 Advance with Temperature Probe	230 V / 50-60 Hz	SA20500584
AREX 5 Advance with Temperature Probe	115 V / 60 Hz	SA20510584
AREX 5 Advance with Temperature Probe, Rod and clamp	230 V / 50-60 Hz	SC20500584
AREX 5 Advance with Temperature Probe, Rod and clamp	115 V / 60 Hz	SC20510584

AREX 5 Digital

Digital hot plate stirrer with white LED display ensuring precise settings and clear readout of the working conditions. The fast heating, 135 mm diameter CerAlTop™ plate protects from chemicals, scratches and enhances the lifetime of the unit. The brushless motor guarantees powerful stirring performance.

Safety and Durability

A security message "Hot" and an over-temperature protection system together with insulating disk and the robust die-cast aluminum housing ensure superior safety and resistance. IP 42 certified.

Precise Thermoregulation

Excellent thermoregulation performance with Pt100, Pt1000 Probe and VTF.

- Volume (H₂O) 20 L
- Stirring speed up to 1500 rpm
- Temperature from room temperature to 310 °C
- Timer
- External connection Pt 100 and Pt 1000 Probes
- External connection VTF



Configurations - AREX 5 Digital



AREX 5 Digital	230 V / 50-60 Hz	F20500580
AREX 5 Digital	115 V / 60 Hz	F20510580
AREX 5 Digital with Temperature Probe	230 V / 50-60 Hz	SA20500580
AREX 5 Digital with Temperature Probe	115 V / 60 Hz	SA20510580
AREX 5 Digital with Temperature Probe, Rod and clamp	230 V / 50-60 Hz	SC20500580
AREX 5 Digital with Temperature Probe, Rod and clamp	115 V / 60 Hz	SC20510580
AREX 5 Digital with VTF	230 V / 50-60 Hz	SB20500580
AREX 5 Digital with VTF	115 V / 60 Hz	SB20510580

AREX 5

Robust and versatile hot plate stirrer with 135 mm diameter CerAlTop™ plate that protects from chemicals, scratches and enhances the lifetime of the unit. The brushless motor guarantees powerful stirring performance.

Safety and Durability

Two illuminated indicators always inform the operator when the heating is on. The insulating disk and the robust die-cast aluminum housing ensure superior resistance. IP 42 certified.

Precise Thermoregulation

Excellent thermoregulation of the sample $\pm 0.5\text{ }^{\circ}\text{C}$ with the VTF.

- Volume (H₂O) 20 L
- Stirring speed up to 1500 rpm
- Temperature from room temperature to 310 °C
- Timer
- External connection VTF



Configurations - AREX 5



AREX 5	230 V / 50-60 Hz	F20500570
AREX 5	115 V / 60 Hz	F20510570
AREX 5 with VTF	230 V / 50-60 Hz	SA20500570
AREX 5 with VTF	115 V / 60 Hz	SA20510570

ARE 5

Entry-level, reliable and robust hot plate stirrer with powerful stirring performance thanks to the brushless motor and the SpeedServo™ technology. ARE 5 is a reference for many laboratories around the world ranging from university, research centers to industrial.

Safety and Durability

Two illuminated indicators always inform the operator when the heating is on. The insulating disk and the robust die-cast aluminum housing ensure superior resistance. IP 42 certified.

Reliable

Aluminum alloy top plate (135 mm diameter) ensures a great temperature homogeneity and optimum heat transfer across the entire surface.

- Volume (H₂O) 15 L
- Stirring speed up to 1500 rpm
- Temperature from room temperature to 310 °C



ARE 5

230 V / 50-60 Hz

F20500560

ARE 5

115 V / 60 Hz

F20510560

Accessories - ARE-AREX 5 Series

	AREX 5 Advance	AREX 5 Digital	AREX 5	ARE 5
A00001062 Magnetic stir bar, Ø 3x6 mm	•	•	•	•
A00001063 Magnetic stir bar, Ø 4,5x12 mm	•	•	•	•
A00001057 Magnetic stir bar, Ø 6x20 mm	•	•	•	•
A00001056 Magnetic stir bar, Ø 6x35 mm	•	•	•	•
A00000356 Magnetic stir bar, Ø 8x40 mm	•	•	•	•
A00001061 Magnetic stir bar, Ø 10x60 mm	•	•	•	•
A00000336 Magnetic cross shape stir bar, Ø 10x5 mm	•	•	•	•
A00000352 Magnetic cross shape stir bar, Ø 20x8 mm	•	•	•	•
A00000354 Magnetic disc stir bar, Ø 10x6 mm	•	•	•	•
A00000268 Temperature Probe AISI 316 Ti Ø 3 mm	•	•		
A00000349 Temperature Probe glass-coated Ø 5 mm	•	•		
A00000458 Pt1000 in AISI 316 Ti Ø3 mm	•	•		
F208B0063 VTF Digital Thermoregulator	•	•	•	
A00000382 Extension for support rod	•	•	•	•
A00000280 Clampe for the Probee	•	•		
A00000351 Maniglia per rimozione AluBlock	•	•	•	•
A00001069 Support rod	•	•	•	•

AM4 Digital

Multi-position digital hotplate stirrer to manage in parallel four heating plates independently, up to a volume of 20 L each. The brushless motor guarantees powerful stirring performance while the SpeedServo™ system ensures constant speed even when the viscosity changes. The 135 mm diameter CerAlTop™ plates, made of aluminum alloy coated with ceramic, ensure temperature homogeneity and optimum resistance to chemical agents.

Safety and Durability

A security message "Hot" and an over-temperature protection system together with an insulating disk and robust die-cast aluminum housing ensure superior safety and resistance.

Precise Thermoregulation

Excellent thermoregulation performance with Pt100, Pt1000 Probe and VTF.

- Volume (H₂O) 20 L (x4)
- Stirring speed from 50 to 1500 rpm
- Temperature from room temperature to 310 °C
- External Connection Pt100 and Pt1000 probes
- External connection VTF



Configurations - AM 4 Digital



AM 4 Digital



AM 4 with Temperature Probe,
Rod and Clamp



AM 4 Digital with Temperature Probe, Rod and clamp

230 V / 50-60 Hz

F20500600

AM 4 Digital with Temperature Probe, Rod and clamp

230 V / 50-60 Hz

SA20500600

AM 4

Reliable, robust, and versatile multi-position hotplate stirrer with powerful stirring performance thanks to the brushless motor and the SpeedServo™ technology.

Safety and Durability

Four illuminated indicators always inform the operator when the heating is on. The insulating disk and the robust die-cast aluminum housing ensure superior resistance.

Reliable

Aluminum alloy top plates (135 mm diameter) ensure a great temperature homogeneity and optimum heat transfer across the entire surface.

- Volume (H₂O) 15 L (x4)
- Stirring speed up to 1500 rpm
- Temperature from room temperature to 310 °C



AM4

230 V / 50-60 Hz

F20500590

Accessories - AM4 Series

	AM4 Digital	AM4
A00001062 Magnetic stir bar, Ø 3x6 mm	•	•
A00001063 Magnetic stir bar, Ø 4,5x12 mm	•	•
A00001057 Magnetic stir bar, Ø 6x20 mm	•	•
A00001056 Magnetic stir bar, Ø 6x35 mm	•	•
A00000356 Magnetic stir bar, Ø 8x40 mm	•	•
A00001061 Magnetic stir bar, Ø 10x60 mm	•	•
A00000336 Magnetic cross shape stir bar, Ø 10x5 mm	•	•
A00000352 Magnetic cross shape stir bar, Ø 20x8 mm	•	•
A00000354 Magnetic disc stir bar, Ø 10x6 mm	•	•
A00000268 Temperature Probe AISI 316 Ti Ø 3 mm	•	
A00000349 Temperature Probe glass-coated Ø 5 mm	•	
A00000458 Temperature Probe Pt 1000 Ø3 mm	•	
F208B0063 VTF Digital Thermoregulator	•	
A00000382 Extension for support rod	•	
A00000280 Clamp for the Probe	•	
A00000351 Handle for AluBlock removal	•	•
A00001069 Support rod	•	•









PTFE Safety Cover - Accessories

PTFE safety cover are designed to increase protection and reduce heat loss when working with round bottom flasks and Velp hemispheric bowls.

PTFE Safety Cover Hemispheric Bowl 50 ml	A00000342*	PTFE Safety Cover Hemispheric Bowl 500 ml	A00000345*
PTFE Safety Cover Hemispheric Bowl 100 ml	A00000343*	PTFE Safety Cover Hemispheric Bowl 100 ml	A00000346*
PTFE Safety Cover Hemispheric Bowl 250 ml	A00000344*	* Non disponibile in USA, Messico e Canada	

HEMISPHERIC BOWLS™ - Accessories

The Hemispheric Bowls are the most suitable solution to replace oil baths and mantles in order to perform clean and safe analysis with round bottom flasks. Velp Hemispheric Bowl precisely fit the 135 mm diameter plate and the flask surface, ensuring the fastest heat transfer

Volume			Volume		
	A00000373	25 ml		A00000333	500 ml
	A00000330	50 ml		A00000334	1 L
	A00000331	100 ml		A00000374	3 L
	A00000332	250 ml		A00000375	5 L















ALUBLOCKS™ - Accessories

The new MonoAluBlock™ and MultiAluBlock™ permits to perform numerous reactions, reducing time and bench space also achieving the highest stirring and heating performances.

MonoAluBlock™ are the ideal solution for all the application that require to stir multiple vials of the same dimensions.

MultiAluBlock™ consist of small combinable segments in order to accommodate different sizes of vials at the same time. The user can select the most suitable mix for his application

MonoAluBlock™		Number of places	Volume (ml)	Vial Diameter (mm)	Hole Depth (mm)
	A00000340	17	40	28	43
	A00000339	17	30	28	30
	A00000338	17	20	28	24
	A00000341	40	2	12	14

MultiAluBlock™		Number of places	Volume (ml)	Vial Diameter (mm)	Hole Depth (mm)
	A00000324	4	40	28	43
	A00000325	4	30	28	30
	A00000326	4	20	28	24
	A00000327	4	16	21	31
	A00000328	8	8	17	26
	A00000329	11	4	15	20
	A00000337	11	2	12	14
	A00000323	1	-	-	-

AREC 4 Digital

Digital hotplate stirrer with white LED display ensuring precise settings and clear readout of the working conditions. The robust 4-inch ceramic top plate protects from chemicals, scratches and enhances the lifetime of the unit. The brushless motor guarantees powerful stirring performance. The ideal solution for laboratories with limited bench space.

Precise Thermoregulation

Optimum thermoregulation of the medium with Pt100, Pt1000 Probes ($\pm 1\text{ }^\circ\text{C}$) and VTF Digital Thermoregulator ($\pm 0.5\text{ }^\circ\text{C}$).

Powerful Stirring

Advanced brushless motor ensuring constant stirring from 100 up to 1500 rpm.

Safe and Resistant

A security message "Hot" and an over-temperature protection system. The robust ceramic top offers exceptional resistance and it is easy to clean with a simple wipe-down.

- Volume (H₂O) 5 L
- Stirring speed up to 1500 rpm
- Temperature from room temperature to 550 °C
- External connection Pt100 e Pt1000 Probes
- External connection VTF



Configurations - AREC 4 Digital



AREC 4 Digital	230 V / 50-60 Hz	F20500671
AREC 4 Digital	115 V / 60 Hz	F20510671
AREC 4 Digital with Temperature Probe	230 V / 50-60 Hz	SA20500671
AREC 4 Digital with Temperature Probe	115 V / 60 Hz	SA20510671
AREC 4 Digital with Temperature Probe, rod and clamp	230 V / 50-60 Hz	SC20500671
AREC 4 Digital with Temperature Probe, rod and clamp	115 V / 60 Hz	SC20510671
AREC 4 Digital with VTF	230 V / 50-60 Hz	SB20500671
AREC 4 Digital with VTF	115 V / 60 Hz	SB20510671

AREC 4

Entry-level hotplate stirrer, featuring a ceramic top plate, a powerful brushless motor and the SpeedServo™ technology, for consistent heating and stirring performance. AREC 4 is designed for everyday lab use. The compact size saves valuable bench space.

Reliable and Efficient

Advanced heating technology ensures uniform temperature distribution and efficient heating performance. Brushless motor provides consistent stirring.

Safe and Resistant

Two illuminated indicators always inform the operator when the heating is on. The robust ceramic top offers exceptional resistance and it is easy to clean with a simple wipe-down.

- Volume (H₂O) 5 L
- Stirring speed up to 1500 rpm
- Temperature from room temperature to 550 °C



AREC 4

230 V / 50-60 Hz

F20500670

AREC 4

115 V / 60 Hz

F20510670

AREC 7 Advance

Advanced hot plate stirrer that delivers powerful performance, precise thermoregulation, and smart connectivity to support reliable and efficient lab work. The 7x7-inch ceramic top ensures excellent chemical resistance and easy cleaning, while the intuitive interface with capacitive buttons and tempered glass panel enables effortless control of all parameters. Set temperature ramps, monitor viscosity, and optimize your workflow with confidence.

Elevating laboratory standards

Switch between multiple heating and stirring modes and choose the connectivity option that suits your workflow best: remote control via Velp Ermes Cloud Platform (Wi-Fi) or local data management via PC and USB flash drive (USB-C).

Precise Thermoregulation

Excellent temperature accuracy and reproducibility with Pt100, Pt1000 Probe, and VTF.

Powerful Stirring

Brushless motor and strong magnetic coupling ensure consistent, maintenance-free stirring.

Safe and Resistant

Multiple safety features, including: safety lock button external Probee safety alarm, over-temperature protection and safety circuits, and the "hot" warning above 50°C.

- Volume (H₂O) 20 L
- Stirring speed from 30 to 1700 rpm
- Temperature from room temperature to 550 °C
- Ramps up to 9 temperatures, up to 9 speeds
- Timer & Auto-reverse
- Safety Lock
- External connection Pt 100, Pt 1000 Probes and VTF



ERMES ENABLED

Configurations - AREC 7 Advance



AREC 7 Advance



AREC 7 Advance with Temperature Probe



AREC 7 Advance with Temperature Probe, Rod and Clamp



3 YEARS WARRANTY

AREC 7 Advance	230 V / 50-60 Hz	F20500682
AREC 7 Advance	115 V / 60 Hz	F20510682
AREC 7 Advance with Temperature Probe	230 V / 50-60 Hz	SA20500682
AREC 7 Advance with Temperature Probe	115 V / 60 Hz	SA20510682
AREC 7 Advance with Temperature Probe, Rod and clamp	230 V / 50-60 Hz	SC20500682
AREC 7 Advance with Temperature Probe, Rod and clamp	115 V / 60 Hz	SC20510682

Includes: Magnetic stir bar Ø 8x40 mm.

AREC 7 Digital

Digital hotplate stirrer with white LED display ensuring precise settings and clear readout of the working conditions. The robust 7-inch ceramic top plate protects from chemicals and scratches and enhances the lifetime of the unit. The brushless motor guarantees powerful stirring performance.

Precise Thermoregulation

Excellent thermoregulation performance with Pt100, Pt1000 Probe, and VTF.

Powerful Stirring

Advanced brushless motor ensuring constant stirring from 100 up to 1500 rpm.

Safe and Resistant

A security message "Hot" and an over-temperature protection system. The robust ceramic top offers exceptional resistance and it is easy to clean with a simple wipe-down.

- Volume (H₂O) 15 L
- Stirring speed up to 1500 rpm
- Temperature from room temperature to 550 °C
- External connection Pt 100 and Pt 1000 Probe
- External connection VTF



Configurations - AREC 7 Digital



AREC 7 Digital	230 V / 50-60 Hz	F20500681
AREC 7 Digital	115 V / 60 Hz	F20510681
AREC 7 Digital	100 V / 50-60 Hz	F20580681
AREC 7 Digital with Temperature Probe	230 V / 50-60 Hz	SA20500681
AREC 7 Digital with Temperature Probe	115 V / 60 Hz	SA20510681
AREC 7 Digital with Temperature Probe, Rod and clamp	230 V / 50-60 Hz	SC20500681
AREC 7 Digital with Temperature Probe, Rod and clamp	115 V / 60 Hz	SC20510681
AREC 7 Digital with VTF	230 V / 50-60 Hz	SB20500681
AREC 7 Digital with VTF	115 V / 60 Hz	SB20510681

AREC 7

Robust and reliable analog hotplate stirrer, for consistent heating and stirring performance in everyday lab use.

Reliable and Efficient

Advanced heating technology ensures uniform temperature distribution and efficient heating performance. A brushless motor and the SpeedServo™ technology provide consistent stirring.

Safe and Resistant

A warning icon illuminates when the plate temperature exceeds 50°C and the heating function is inactive. The robust ceramic top offers exceptional resistance and it is easy to clean with a simple wipe-down.

- Volume (H₂O) 15 L
- Stirring speed up to 1500 rpm
- Temperature from room temperature to 550 °C



AREC 7	230 V / 50-60 Hz	F20500680
AREC 7	115 V / 60 Hz	F20510680
AREC 7	100 V / 50-60 Hz	F20580680



Temp

75.9



1-4



00:10:00

AREX 5 Advance
Heating Magnetic Stirrer



velp®

AREC 10 Advance

Advanced hot plate stirrer that delivers powerful performance, precise thermoregulation, and smart connectivity to support reliable and efficient lab work. The spacious 10x10 ceramic top ensures excellent chemical resistance and is ideal for larger vessels or high-volume tasks. The intuitive interface with capacitive buttons and tempered glass panel enables effortless control of all parameters. Set temperature ramps, monitor viscosity, and optimize your workflow with confidence.

Elevating Laboratory Standards

Switch between multiple heating and stirring modes and choose the connectivity option that suits your workflow best: remote control via Velp Ermes Cloud Platform (Wi-Fi) or local data management via PC and USB flash drive (USB-C).

Precise Thermoregulation

Excellent temperature accuracy and reproducibility with Pt100, Pt1000 Probe, and VTF.

Powerful Stirring

Brushless motor and strong magnetic coupling ensure consistent, maintenance-free stirring.

Safe and Resistant

Multiple safety features, including: safety lock button external Probee safety alarm, over-temperature protection and safety circuits, and the "hot" warning above 50°C.

- Volume (H₂O) 25 L
- Stirring speed from 30 to 1700 rpm
- Temperature from room temperature to 550 °C
- Ramps up to 9 temperatures, up to 9 speeds
- Timer & Auto-reverse
- Safety Lock
- External connection Pt 100, Pt 1000 Probes



ERMES ENABLED

Configurations - AREC 10 Advance



AREC 10 Advance	230 V / 50-60 Hz	F20500692
AREC 10 Advance	115 V / 60 Hz	F20510692
AREC 10 Advance with Temperature Probe	230 V / 50-60 Hz	SA20500692
AREC 10 Advance with Temperature Probe	115 V / 60 Hz	SA20510692
AREC 10 Advance with Temperature Probe, Rod and clamp	230 V / 50-60 Hz	SC20500692
AREC 10 Advance with Temperature Probe, Rod and clamp	115 V / 60 Hz	SC20510692

AREC 10 Digital

Digital hotplate stirrer with white LED display ensuring precise settings and clear readout of the working conditions. The robust 10-inch ceramic top plate protects from chemicals, scratches and enhances the lifetime of the unit. The brushless motor guarantees powerful stirring performance. The ideal solution for laboratories requiring a spacious working surface.

Precise Thermoregulation

Optimum thermoregulation of the medium with Pt100, Pt1000 Probes ($\pm 1\text{ }^{\circ}\text{C}$) and VTF Digital Thermoregulator ($\pm 0.5\text{ }^{\circ}\text{C}$).

Powerful Stirring

Advanced brushless motor ensuring constant stirring from 100 up to 1500 rpm.

Safe and Resistant

A security message "Hot" and an over-temperature protection system. The robust ceramic top offers exceptional resistance and it is easy to clean with a simple wipe-down.

- Volume (H₂O) 25 L
- Stirring speed Up to 1500 rpm
- Temperature from room temperature to 550 °C
- External connection VTF
- External connection Pt100 and Pt1000 Probe



Configurations - AREC 10 Digital



AREC 10 Digital



AREC 10 Digital with Temperature Probe



AREC 10 Digital with Temperature Probe, Rod and Clamp



AREC 10 Digital with VTF



AREC 10 Digital	230 V / 50-60 Hz	F20500691
AREC 10 Digital	115 V / 60 Hz	F20510691
AREC 10 Digital	100 V / 50-60 Hz	F20580691
AREC 10 Digital with Temperature Probe	230 V / 50-60 Hz	SA20500691
AREC 10 Digital with Temperature Probe	115 V / 60 Hz	SA20510691
AREC 10 Digital with Temperature Probe, Rod and clamp	230 V / 50-60 Hz	SC20500691
AREC 10 Digital with Temperature Probe, Rod and clamp	115 V / 60 Hz	SC20510691
AREC 10 Digital with VTF	230 V / 50-60 Hz	SB20500691
AREC 10 Digital with VTF	115 V / 60 Hz	SB20510691

Accessories - AREC Series

	AREC 4 Digital	AREC 4	AREC 7 Advance	AREC 7 Digital	AREC 7	AREC 10 Advance	AREC 10 Digital
A00000273 Hemispheric bowl for 50 ml	•	•	•	•	•	•	•
A00000258 Hemispheric bowl for 100 ml	•	•	•	•	•	•	•
A00001071 Hemispheric bowl for 250 ml	•	•	•	•	•	•	•
A00001072 Hemispheric bowl for 500 ml	•	•	•	•	•	•	•
A00001073 Hemispheric bowl for 1000 ml	•	•	•	•	•	•	•
A00001056 Magnetic stir bar Ø6x35 mm	•	•	•	•	•	•	•
A00000356 Magnetic stir bar Ø8x40 mm	•	•	•	•	•	•	•
A00000387 Magnetic stir bar Ø8x50 mm	•	•	•	•	•	•	•
A00001061 Magnetic stir bar Ø10x60 mm	•	•	•	•	•	•	•
A00000355 Magnetic disc stir bar Ø20x10 mm	•	•	•	•	•	•	•
A00001069 Support rod	•	•	•	•	•	•	•
A00000382 Extension for support rod	•	•	•	•	•	•	•
A00000280 Clamp for PT100 probe	•		•	•		•	•
A00000268 Temperature Probe AISI 316 Ti Ø 3 mm	•		•	•		•	•
A00000349 Temperature Probe glass coated Ø 5 mm	•		•	•		•	•
F208B0063 VTF Digital Thermoregulator	•		•	•		•	•
E00010012 Velp Ermes 1 Year Connection			•			•	
E00010036 Velp Ermes 3 Years Connection			•			•	

MULTI-HS 15 Digital

Digital multi-position magnetic stirrer with heating designed to guarantee excellent stirring and heating performance for application with 15 positions working under identical conditions. The MULTI-HS presents exclusive features such as timer, autoreverse, safety lock, SpeedServo™ technology and CerATop™ plate.

Excellent Performance

The brushless motors ensure longevity and guarantee constant speed in all positions.

Safe and Programmable

Safe hot plate warnings when the plate temperature is above 50 °C. Lock feature to prevent unintentional modifications. Unattended stirring from 1 minute to 99 h : 59 minutes.

Easy to Use

Easy to operate digital interface with icons. An acoustic signal/sound informs you when the countdown is over.

- Volume (H₂O) 250 ml (x15)
- Stirring speed from 100 to 1000 rpm
- Temperature from room temperature to 120 °C
- Timer & Auto-reverse
- Safety Lock



MULTI-HS 15 Digital

230 V / 50-60 Hz

F20500531

MULTI-HS 15 Digital

115 V / 60 Hz

F20510531



MULTI-HS 6 Digital

Digital multi-position magnetic stirrer with heating designed to guarantee excellent stirring and heating performance for application with 6 positions working under identical conditions. The MULTI-HS presents exclusive features such as timer, autoreverse, safety lock, SpeedServo™ technology and CerATop™ plate.

Excellent Performance

The brushless motors ensure longevity and guarantee constant speed in all positions.

Safe and Programmable

Safe hot plate warnings when the plate temperature is above 50 °C. Lock feature to prevent unintentional modifications. Unattended stirring from 1 minute to 99 h : 59 minutes.

Easy to Use

Easy to operate digital interface with icons. An acoustic signal/sound informs you when the countdown is over.

- Volume (H₂O) 400 ml (x6)
- Stirring speed from 100 to 1000 rpm
- Temperature from room temperature to 120 °C
- Timer & Auto-reverse
- Safety Lock



MULTI-HS 6 Digital

230 V / 50-60 Hz

F20500530

MULTI-HS 6 Digital

115 V / 60 Hz

F20510530

Accessories - MULTI-HS

	MULTI-HS 6 Digital	MULTI-HS 15 Digital
A00001056 Magnetic stir bar Ø 6x35 mm	•	•
A00001057 Magnetic stir bar Ø 6x20 mm	•	•

VTF

The VTF thermoregulator guarantees premium performance in terms of temperature control with an accuracy of ± 0.5 °C. It automatically adjusts the thermoregulation to different factors such as power, load and thermal dispersion.

Easy to Use

The VTF is equipped with a unique and innovative integrated system to simplify installation on the support rod.

- Temperature from - 10 to 300 °C
- Timer from 0 minute to 24 : 59 hours



VTF

12 V dc

F208B0063

Accessories - VTF

	VTF
A0000002 Probe extension cable, 1 m	•
A0000003 Glass probe	•
A0000280 Clamp for Pt100 Probe	•
A00001069 Support rod	•

Heating Plates

RC 5

Single-position heating plate with aluminum top and temperature regulation. It is designed for the longest lifespan and guarantees excellent resistance to chemicals. It accepts different combinations of AluBlocks™ that can maximize temperature control and save handling time.

Safety and Durability

Two illuminated indicators always inform the operator when the heating is on. The insulating disk and the robust die-cast aluminum housing ensure superior resistance. IP 42 certified.

Reliable

Aluminum alloy top plate (135 mm diameter) ensures a great temperature homogeneity and optimum heat transfer across the entire surface.

- Volume (H₂O) 15 L
- Temperature range from room temperature to 310 °C



3 YEARS WARRANTY

RC 5

RC 5

230 V / 50-60 Hz

115 V / 60 Hz

F20700610

F20710610



RC2

Two-position heating plate with aluminum top and temperature regulation. It is designed for the longest lifespan and guarantees excellent resistance to chemicals. It accepts different combinations of AluBlocks™ that can maximize temperature control and save handling time.

Safe and Resistant

Two illuminated indicators always inform the operator when the heating is on. The insulating disk and the robust die-cast aluminum housing ensure superior resistance.

Reliable

Aluminum alloy top plates (135 mm diameter) ensure a great temperature homogeneity and optimum heat transfer across the entire surface.

- Volume (H₂O) 15 L (x2)
- Temperature range from room temperature to 310 °C



3 YEARS WARRANTY

RC 2

RC 2

230 V / 50-60 Hz

115 V / 60 Hz

F20700620

F20710620



REC 7 Digital

Digital heating plate with a ceramic top and temperature regulation. It is designed for durability and guarantees excellent resistance to chemicals. It is ideal for everyday laboratory heating tasks.

Reliable and Efficient

Advanced heating technology ensures uniform temperature distribution and efficient heating performance. The digital display for precise temperature settings up to 550°C.

Safe and Resistant

A security message "Hot" and an over-temperature protection system. The robust ceramic top offers exceptional resistance and it is easy to clean with a simple wipe-down.

- Volume (H₂O) 15 L
- Temperature from room temperature to 550 °C



REC 7 Digital	230 V / 50-60 Hz	F20700683
REC 7 Digital	115 V / 60 Hz	F20710683
REC 7 Digital	100 V / 50-60 Hz	F20780683

REC 10 Digital

Digital heating plate with a spacious ceramic surface, designed to guarantee precise temperature control, durability and excellent resistance to chemicals.

Reliable and Efficient

Advanced heating technology ensures uniform temperature distribution and precise thermoregulation of the medium with Pt100, Pt1000 probes (± 1 °C) and VTF (± 0.5 °C).

Safe and Resistant

A security message "Hot" and an over-temperature protection system. The robust ceramic top offers exceptional resistance and it is easy to clean with a simple wipe-down.

- Volume (H₂O) 25 L
- Temperature from room temperature to 550 °C



REC 10 Digital	230 V / 50-60 Hz	F20700693
REC 10 Digital	115 V / 60 Hz	F20710693
REC 10 Digital	100 V / 50-60 Hz	F20780693

Accessories - Heating Plates

	RC 5	RC 2	REC 7	REC 10
A00000373 Hemispheric bowl for 25 ml flasks	•	•		
A00000330 Hemispheric bowl for 50 ml flasks	•	•		
A00000273 Hemispheric bowl for 50 ml flasks			•	•
A00000331 Hemispheric bowl for 100 ml flasks	•	•		
A00000258 Hemispheric bowl for 100 ml flasks			•	•
A00000332 Hemispheric bowl for 250 ml flasks	•	•		
A00001071 Hemispheric bowl for 250 ml flasks			•	•
A00000333 Hemispheric bowl for 500 ml flasks	•	•		
A00001072 Hemispheric bowl for 500 ml flasks			•	•
A00001073 Hemispheric bowl for 1000 ml flasks			•	•
A00000334 Hemispheric bowl for 1000 ml flasks	•	•		
A00000374 Hemispheric bowl for 3 L flasks	•	•		
A00000375 Hemispheric bowl for 5 L flasks	•	•		
A00000323 MultiAluBlock™ Base Ø135 mm	•	•		
A00000324 MultiAluBlock™, 4 pos. Ø 28 x h 43 mm	•	•		
A00000325 MultiAluBlock™, 4 pos. Ø 28 x h 30 mm	•	•		
A00000326 MultiAluBlock™, 4 pos. Ø 28 x h 24 mm	•	•		
A00000327 MultiAluBlock™, 4 pos. Ø 21 x h 31 mm	•	•		
A00000328 MultiAluBlock™, 8 pos. Ø 17 x h 26 mm	•	•		
A00000329 MultiAluBlock™, 11 pos. Ø 15 x h 20 mm	•	•		
A00000337 MultiAluBlock™, 11 pos. Ø 12 x h 14 mm	•	•		
A00000340 MonoAluBlock, 17 pos. Ø 28 x h 43 mm	•	•		
A00000339 MonoAluBlock, 17 pos. Ø 28 x h 30 mm	•	•		
A00000338 MonoAluBlock, 17 pos. Ø 28 x h 24 mm	•	•		
A00000341 MonoAluBlock, 40 pos. Ø 12 x h 14 mm	•	•		
A00000342 PTFE Safety cover for bowl 50 ml	•	•		
A00000343 PTFE Safety cover for bowl 100 ml	•	•		
A00000344 PTFE Safety cover for bowl 250 ml	•	•		
A00000345 PTFE Safety cover for bowl 500 ml	•	•		
A00000346 PTFE Safety cover for bowl 1000 ml	•	•		
A00001069 Support rod	•	•	•	•
A00000382 Extension for support rod		•	•	•
A00000351 Handle for AluBlock removal	•	•		

Overhead Stirrers

OHS 200 Advance

Powerful Wi-Fi Enabled Laboratory overhead stirrer with a TFT 3.5" Display that shows all setting information at a glance. Wi-Fi Connection to Velp Ermes Platform allows remote monitoring and control of operations in real-time. USB interface for use with optional PC software to data log, monitor, turn off/on. Pt100 probe included allowing real-time temperature monitoring.

Constant Torque at any Speed

The powerful brushless motor and electronic control guarantee 200 Ncm torque (speed gear 1) at any speed. Double speed gear for an excellent performance for high volumes and high viscosities.

Easy to Use

Smartchuck™ system simplifies the shaft accommodation without tools and with one hand only.

Safe and Resistant

The resistant sealed housing guarantees durability in the most aggressive environments. IP 54 certified.

- Volume (H₂O) 100 L
- Viscosity Up to 100.000 mPa*s
- Torque Gear 1: 200 Ncm
- Stirring speed: Gear 1: 6-400 rpm / Gear 2: 30-2000 rpm
- Timer and programmable methods
- Safety Lock
- External connection Pt100 probe

OHS 200 Advance

OHS 200 Advance



3 YEARS WARRANTY

ERMES ENABLED

230 V / 50-60 Hz

F20100480

115 V / 60 Hz

F20110480

OHS 100 Advance

Powerful Wi-Fi Enabled Laboratory overhead stirrer with a TFT 3.5" Display that shows all setting information at a glance. Wi-Fi Connection to Velp Ermes Platform allows remote monitoring and control of operations in real-time. USB interface for use with optional PC software to data log, monitor, turn off/on. Pt100 probe included allowing real-time temperature monitoring.

Constant Torque at any Speed

The powerful brushless motor and electronic control guarantee 100 Ncm torque at any speed.

Easy to Use

Smartchuck™ system simplifies the shaft accommodation without tools and with one hand only.

Safe and Resistant

The resistant sealed housing guarantees durability in the most aggressive environments. IP 54 certified.

- Volume (H₂O) 100 L
- Viscosity Up to 70.000 mPa*s
- Torque Gear 1: 100 Ncm
- Stirring speed from 30 to 1300 rpm
- Timer and programmable methods
- Safety Lock
- External connection Pt100 probe

OHS 100 Advance

OHS 100 Advance



3 YEARS WARRANTY

ERMES ENABLED

230 V / 50-60 Hz

F20100481

115 V / 60 Hz

F20110481

OHS 60 Advance

Powerful Wi-Fi Enabled Laboratory overhead stirrer with a TFT 3.5" Display that shows all setting information at a glance. Wi-Fi Connection to Velp Ermes Platform allows remote monitoring and control of operations in real-time. USB interface for use with optional PC software to data log, monitor, turn off/on. Pt100 probe included allowing real-time temperature monitoring.

Constant Torque at any Speed

The powerful brushless motor and electronic control guarantee 60 Ncm torque at any speed.

Easy to Use

Smarchuck™ system simplifies the shaft accommodation without tools and with one hand only.

Safe and Resistant

The resistant sealed housing guarantees durability in the most aggressive environments. IP 54 certified.

- Volume (H₂O) 40 L
- Viscosity Up to 50.000 mPa*s
- Torque 60 Ncm
- Stirring speed from 30 to 2000 rpm
- Timer and programmable methods
- Safety Lock
- External connection Pt100 probe



3 YEARS WARRANTY

ERMES ENABLED

OHS 60 Advance

230 V / 50-60 Hz

F20100482

OHS 60 Advance

115 V / 60 Hz

F20110482

OHS 200 Digital

Powerful overhead stirrer with digital display to precisely set stirring speed and timer. Dedicated 4 segment LED display showing the torque trend. Intuitive knob to navigate the menu and start stop operations.

Constant Torque at any Speed

The powerful brushless motor and electronic control guarantee 200 Ncm torque (speed gear 1) at any speed. Double speed gear for an excellent performance for high volumes and high viscosities.

Easy to Use

Smarchuck™ system simplifies the shaft accommodation without tools and with one hand only.

Safe and Resistant

The resistant sealed housing guarantees durability in the most aggressive environments. IP 54 certified.

- Volume (H₂O) 100 L
- Viscosity Up to 100.000 mPa*s
- Torque Gear 1: 200 Ncm
- Stirring speed Gear 1: 6-400 rpm Gear 2: 30-2000 rpm
- Timer
- Safety Lock



3 YEARS WARRANTY

OHS 200 Digital

230 V / 50-60 Hz

F20100490

OHS 200 Digital

115 V / 60 Hz

F20110490

OHS 100 Digital

Powerful overhead stirrer with digital display to precisely set stirring speed and timer. Dedicated 4 segment LED display showing the torque trend. Intuitive knob to navigate the menu and start stop operations.

Constant Torque at any Speed

The powerful brushless motor and electronic control guarantee 100 Ncm torque at any speed.

Easy to use

Smartchuck™ system simplifies the shaft accommodation without tools and with one hand only.

Safe and Resistant

The resistant sealed housing guarantees durability in the most aggressive environments. IP 54 certified.

- Volume (H₂O) 100 L
- Viscosity Up to 70.000 mPa*s
- Torque Gear 1: 100 Ncm
- Stirring speed from 30 to 1300 rpm
- Timer
- Safety Lock



3 YEARS WARRANTY



OHS 100 Digital

230 V / 50-60 Hz

F20100491

OHS 100 Digital

115 V / 60 Hz

F20110491

OHS 60 Digital

Powerful overhead stirrer with digital display to precisely set stirring speed and timer. Dedicated 4 segment LED display showing the torque trend. Intuitive knob to navigate the menu and start stop operations.

Constant Torque at any Speed

The powerful brushless motor and electronic control guarantee 60 Ncm torque at any speed.

Easy to Use

Smartchuck™ system simplifies the shaft accommodation without tools and with one hand only.

Safe and Resistant

The resistant sealed housing guarantees durability in the most aggressive environments. IP 54 certified.

- Volume (H₂O) 40 L
- Viscosity Up to 50.000 mPa*s
- Torque Gear 1: 60 Ncm
- Stirring speed from 30 to 2000 rpm
- Timer
- Safety Lock



3 YEARS WARRANTY



OHS 60 Digital

230 V / 50-60 Hz

F20100492

OHS 60 Digital

115 V / 60 Hz

F20110492

OHS 40 Digital

Powerful overhead stirrer with digital display to precisely set stirring speed and timer. Dedicated 4 segment LED display showing the torque trend. Intuitive knob to navigate the menu and start stop operations.

Constant Torque at any Speed

The powerful brushless motor and electronic control guarantee 40 Ncm torque at any speed.

Easy to Use

Smartchuck™ system simplifies the shaft accommodation without tools and with one hand only.

Safe and Resistant

The resistant sealed housing guarantees durability in the most aggressive environments. IP 54 certified.

- Volume (H₂O) 25 L
- Viscosity Up to 25.000 mPa*s
- Torque Gear 1: 40 Ncm
- Stirring speed from 30 to 2000 rpm
- Timer
- Safety Lock



OHS 40 Digital

OHS 40 Digital



230 V / 50-60 Hz

115 V / 60 Hz

F20100493

F20110493

OHS 20 Digital

Powerful overhead stirrer with digital display to precisely set stirring speed and timer. Dedicated 4 segment LED display showing the torque trend. Intuitive knob to navigate the menu and start stop operations.

Constant Torque at any Speed

The powerful brushless motor and electronic control guarantee 20 Ncm torque at any speed.

Easy to Use

Smartchuck™ system simplifies the shaft accommodation without tools and with one hand only.

Safe and Resistant

The resistant sealed housing guarantees durability in the most aggressive environments. IP 54 certified.

- Volume (H₂O) 25 L
- Viscosity Up to 10.000 mPa*s
- Torque Gear 1: 20 Ncm
- Stirring speed from 30 to 2000 rpm
- Timer
- Safety Lock



OHS 20 Digital

OHS 20 Digital



230 V / 50-60 Hz

115 V / 60 Hz

F20100494

F20110494

DLH

Digital overhead stirrer suitable for all medium to high-viscosity mixing tasks. The bright display provides easy-to-read details of four important parameters: set speed, actual speed, torque and time.

Safety and Easy to Use

The DLH is an intuitive overhead stirrer ensuring safety with overload, over-current and overheating protection.

Compact and Lightweight

The special technopolymer structure and the IP 40 Protection Rating guarantee chemical resistance and easy handling, being among the lightest overhead stirrer on the market.

- Volume (H₂O) 40 L
- Viscosity Up to 50.000 mPa*s
- Torque 80 Ncm
- Stirring speed from 50 to 2000 rpm
- Timer



DLH

110-230 V / 50-60 Hz

F201A0157

DLS

Digital overhead stirrer suitable for all medium viscosity mixing tasks. The bright display provides easy-to-read details of four important parameters: set speed, actual speed, torque and time.

Safety and Easy to Use

The DLS is an intuitive overhead stirrer ensuring safety with overload, over-current and overheating protection.

Compact and Lightweight

The DLS is an intuitive overhead stirrer ensuring safety with overload, over-current and overheating protection.

- Volume (H₂O) 25 L
- Viscosity Up to 25.000 mPa*s
- Torque 40 Ncm
- Stirring speed from 50 to 2000 rpm
- Timer



DLS

110-230 V / 50-60 Hz

F201A0155

DLS - System

110-230 V / 50-60 Hz

SA201A0155*

* Universal H-Stand, Double Clamp, Stirring Shaft with Propeller included.

PW

Laboratory overhead stirrer with analog control suitable for high viscosity mixing applications. Easy to install and to operate thanks to the hand-tightened chuck requiring no tools.

Safety and Easy to Use

The PW ensures safety with overload, over-current and overheating protection.

Compact and Lightweight

The special technopolymer structure and the IP 40 Protection Rating guarantee chemical resistance and easy handling, being among the lightest overhead stirrer on the market.

- Volume (H₂O) 70 L
- Viscosity Up to 100.000 mPa*s
- Torque 120 Ncm
- Stirring speed from 20 to 1200 rpm



3 YEARS WARRANTY

PW



110-230 V / 50-60 Hz

F201A0150

LH

Laboratory overhead stirrer with analog control suitable for high viscosity mixing applications. Easy to install and to operate thanks to the hand-tightened chuck requiring no tools.

Safety and Easy to Use

The LH ensures safety with overload, over-current and overheating protection.

Compact and Lightweight

The special technopolymer structure and the IP 40 Protection Rating guarantee chemical resistance and easy handling, being among the lightest overhead stirrer on the market.

- Volume (H₂O) 40 L
- Viscosity Up to 50.000 mPa*s
- Torque 80 Ncm
- Stirring speed from 50 to 2000 rpm



3 YEARS WARRANTY

LH



110-230 V / 50-60 Hz

F201A0156

LS

Laboratory overhead stirrer with analog control suitable for medium viscosity mixing applications. Easy to install and to operate thanks to the hand-tightened chuck requiring no tools.

Safety and Easy to Use

The LS ensures safety with overload, over-current and overheating protection.

Compact and Lightweight

The special technopolymer structure and the IP 40 Protection Rating guarantee chemical resistance and easy handling, being among the lightest overhead stirrer on the market.

- Volume (H₂O) 25 L
- Viscosity Up to 25.000 mPa*s
- Torque 40 Ncm
- Stirring speed from 50 to 2000 rpm



LS

LS - System

* Universal H-Stand, Double Clamp, Stirring Shaft with Fixed Blade included.

110-230 V / 50-60 Hz

110-230 V / 50-60 Hz

F201A0151

SA201A0151*

ES

Laboratory overhead stirrer with analog control suitable for low viscosity mixing applications. Easy to install and to operate thanks to the hand-tightened chuck requiring no tools.

Safety and Easy to Use

The ES ensures safety with overload, over-current and overheating protection.

Compact and Lightweight

The special technopolymer structure and the IP 40 Protection Rating guarantee chemical resistance and easy handling, being among the lightest overhead stirrer on the market.

- Volume (H₂O) 15 L
- Viscosity Up to 1.000 mPa*s
- Torque 15 Ncm
- Stirring speed from 50 to 1300 rpm



ES

110-230 V / 50-60 Hz

F201A0152

Accessories - Overhead Stirrers

	OHS Advance	OHS Digital	DLH	DLS	PW	LH	LS	ES
A00001301 Double clamp	•	•	•	•	•	•	•	•
A00001302 Ribbon clamp	•	•	•	•	•	•	•	•
A00001312 Chuck guard OHS	•	•						
A00000372 Support rod for probe	•							
A00000002 Probe extension cable, length 1 m	•							
A00000003 Glass probe for VTF	•							
TA00000394 Kit Pt100 probe XL for OHS	•							
A00000381 IQ/OQ Manual OHS Digital		•						
A00000380 IQ/OQ Manual OHS Digital	•							
A00000391 OHS/ControllerSoft	•							
E00010012 Velp Ermes 1 Year Connection	•							
E00010036 Velp Ermes 3 Years Connection	•							

H-STAND - Accessories

Velp H-Stands are the ideal solution when the overhead stirrer is working on laboratory benches.

We have designed our H-Stand to guarantee the maximum stability thanks to the H-shape of the base and the maximum resistance choosing premium materials such as aluminum and stainless steel, properly treated in order to resist to chemicals and corrosion.

The Telescopic H-Stand facilitates the daily operations being easy-to-use when raising and lowering the overhead stirrer from your sample.



Universal H-Stand



Telescopic H-Stand

Stirring Shafts - Accessories

Overhead stirrers require stirring shaft for precise working. Choosing the correct stirring shaft is an important step to obtain the best stirring performance.

It is important to evaluate the characteristics and the effects on the fluid of the stirring shaft, together with the volume and viscosity:

- Desired type of flow: Axial, Tangential, Radial;
- Speed range of your application.

Stirring Shaft with Floating Blades
(VL - L)

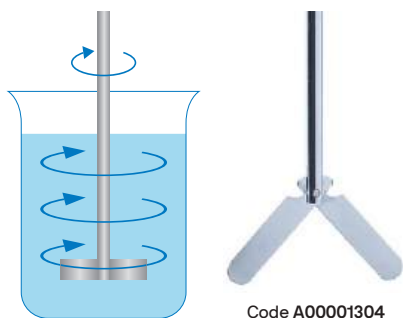

Stirring Shaft with 6-Hole Paddle
(L - M)

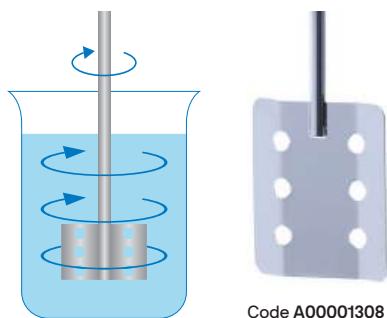

Stirring Shaft with Fixed Blade
(VL - L - M)

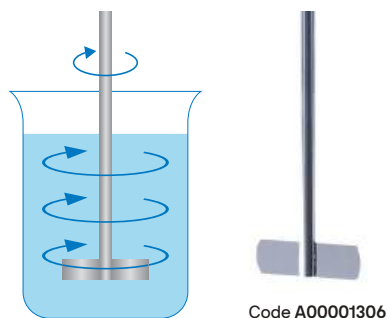

Stirring Shaft with Turbo Propeller
(M - H)

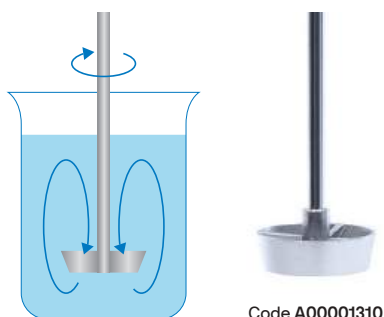

Stirring Shaft with Folding Blade
(VL - L)

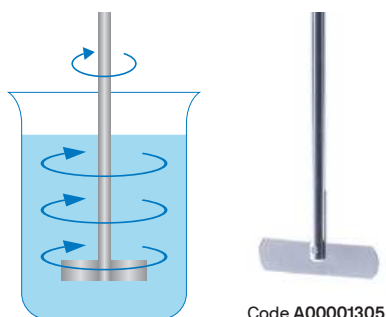

Stirring Shaft with Turbine
(M - H)

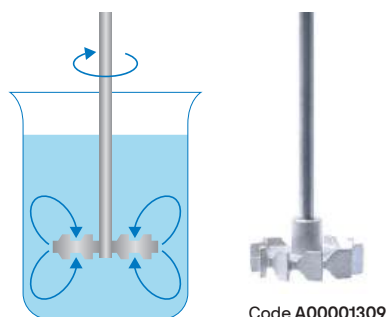

Stirring Shaft with Propeller
(VL - L - M)

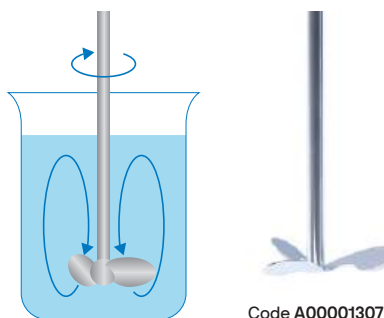

Stirring Shaft with Anchor
(M - H)



Viscosity Range

Range	mPa*s
Very low (VL)	0 - 100
Low (L)	100 - 1,000
Medium (M)	1,000 - 10,000
High (H)	10,000 - 100,000

Sample Viscosity

Sample	mPa*s
Water	1
Kerosene	10
Lubricating Oil	100
Castrol Oil Glycerin	1,000
Shampoo	3,000
Refined Honey	7,000
Body Cream	8,000
Honey	10,000
Chocolate Syrup	25,000
Ketchup	50,000
Toothpaste	70,000
Molasses, Asphalt	100,000

CONTROLLER Advance

Powerful and innovative solution designed to control brushless motors of Reaction Systems of up to 100 L volume. The Controller Advance features a TFT 3.5" Display that shows all setting information at a glance. Wi-Fi Connection to Velp Ermes Platform to monitor status and data logging on the cloud. USB interface for use with optional PC software to data log, monitor, turn off/on. USB also allow Software Updates.

- Timer for unattended operations
- Real time torque, speed and temperature graph monitoring
- Intuitive knob to navigate the menu and start stop operations
- Programmable methods to setup to 4 Time/Speed Ramps.
- Timer
- Safety Lock
- CW/CCW Direction Changes

Accessories - CONTROLLER Advance

A00000391 OHS/ControllerSoft	A00000416 Motor 28 lb*in, 500 rpm , 1/11 HP - 24V
A00000394 Pt100 Probe XL Ø6 500mm	A00000417 Motor 55 lb*in, 250 rpm , 1/11 HP - 24V
A00000415 Motor 10 lb*in, 471 rpm , 1/11 HP - 24V	E00010012 Velp Ermes 1 year Connection
E00010036 Velp Ermes 3 years Connection	



Controller Advance



(not available in USA, Mexico and Canada)

ERMES ENABLED

115-230 V / 50-60 Hz

F201A0500

CONTROLLER Digital

Powerful and innovative solution designed to control brushless motors of Reaction Systems of up to 100 L volume. The Controller Digital features a digital display to set the speed and a 4 segment LED display to monitor torque.

- Timer for unattended operations
- Intuitive knob to navigate the menu and start stop operations
- Clockwise and counterclockwise direction changes.
- Timer
- Safety Lock
- CW/CCW Direction Changes

Accessories - CONTROLLER Digital

A00000415 Motor 10 lb*in, 471 rpm , 1/11 HP - 24V	A00000416 Motor 28 lb*in, 500 rpm , 1/11 HP - 24V
A00000417 Motor 55 lb*in, 250 rpm , 1/11 HP - 24V	



Controller Digital



(not available in USA, Mexico and Canada)

115-230 V / 50-60 Hz

F201A0505

Vortex Mixers

Wizard IR

Vortex mixer featuring the highly innovative and patented IR technology to reduce repetitive strains. IR sensor and Continuous mode available. Large choice of complementary accessories to accommodate tubes, plates and flasks.

Exclusive Ergonomics

The Velp IR sensor uses an infrared system (IR) to detect the presence of the tube and automatically starts vibrating. No pressure is required to maintain vibration, drastically reducing arm stress.

Stable and Robust

Robust low profile design provides exceptional stability. The technopolymer housing and zinc base ensure optimum chemical resistance and excellent stability on the bench.

- Stirring speed up to 3000 rpm
- Patented IR Sensor



Wizard

100÷240 V / 50-60 Hz

F202A0175



Classic

Compact vortex mixer suitable for different mixing requirements, with touch or continuous mode. It is highly resistant to chemicals and has 3 anti-slip rubber feet for stability.

Robust and Convenient

The IP 42 Protection Rating and the technopolymer casing guarantee good chemical resistance against particles and liquids. It uses universal voltage/frequency.

Versatile

Large choice of accessories to suit tubes, plates and flasks. Accessories fit by simple pressure.

- Stirring speed up to 3000 rpm



Classic

100÷240 V / 50-60 Hz

F202A0173



TX4

Exclusive digital vortex mixer featuring the highly innovative and patented IR technology to reduce repetitive strains. The bright digital display ensures precision and reproducibility. The integrated timer allows programming the vortex for unattended operations. Large choice of complementary accessories to accommodate tubes, plates and flasks.

Exclusive Ergonomics

The Velp IR sensor uses an infrared system (IR) to detect the presence of the tube and automatically starts vibrating. No pressure is required to maintain vibration, drastically reducing arm stress.

Stable and Robust

The technopolymer housing and zinc base ensure optimum chemical resistance and excellent stability on the bench.

- Stirring speed up to 3000 rpm
- Patented IR Sensor
- Timer



TX4



100±240 V / 50-60 Hz

F202A0270

ZX4

ZX4 Vortex mixer is highly innovative and patented IR technology reduces repetitive strains. IR sensor and continuous mode available. Large choice of complementary accessories to accommodate tubes, plates and flasks.

Exclusive Ergonomics

The Velp IR sensor uses an infrared system (IR) to detect the presence of the tube and automatically starts vibrating. No pressure is required to maintain vibration, drastically reducing arm stress.

Stable and Robust

The technopolymer housing and zinc base ensure optimum chemical resistance and excellent stability on the bench.

- Stirring speed up to 3000 rpm
- Patented IR Sensor



ZX4



100±240 V / 50-60 Hz

F202A0280

ZX4 and Foam Stands

80±260 V / 50-60 Hz

SA202A0280*

* Stand for 19 microvials Eppendorf 1,5 ml, Customizable soft foam top and Small rubber supporting plate Ø 50mm included

ZX3

Reliable vortex mixer has adjustable stirring speed and touch or continuous mode. ZX3 features large, anti-slip rubber feet to ensure maximum stability. It is also highly resistant to chemicals.

Robust and Convenient

The IP 42 Protection Rating and the technopolymer casing guarantee good chemical resistance against particles and liquids. It uses universal voltage/frequency.

Versatile

Large choice of accessories to suit tubes, plates and flasks. Accessories fit by simple pressure.

- Stirring speed up to 3000 rpm



ZX3

100±240 V / 50-60 Hz

F202A0176

ZX3 and Foam Stands

100±240 V / 50-60 Hz

SA202A0176*

* Stand for 19 microvials Eppendorf 1,5 ml, Customizable soft foam top and Small rubber supporting plate Ø 50mm included

RX3

Basic vortex mixer with fixed stirring speed and touch mode. RX3 features large, anti-slip rubber feet to ensure maximum stability. It is also highly resistant to chemicals.

Robust and Convenient

The IP 42 Protection Rating and the technopolymer casing guarantee high-grade chemical resistance.

- Stirring speed up to 3000 rpm



RX3

100±240 V / 50-60 Hz

F202A0171

ROTAX 6.8 Overhead Mixer

Overhead mixer with LCD speed display, that offers excellent performance for all the applications where rotating, shaking and mixing are required. Rotax 6.8 is resistant to chemical and mechanical corrosion.

Precise and Safe

Rotax 6.8 is designed to automatically stop if blocked. Moreover it is compliant with UNI 10802 and DIN 38414 standards.

- Stirring speed up to 30 rpm



ROTAX 6.8

230 V / 50–60 Hz

F10600118

ROTAX 6.8

115 V / 50–60 Hz

F10610118

Accessories - Vortex Mixers

		Wizard	Classic	TX4	ZX4	ZX3	RX3	ROTAX
	Foam stand for 19 microvials Eppendorf, 1.5 ml A00000012	•	•	•	•	•		
	Customizable soft foam top A00000013	•	•	•	•	•		
	Foam stand for 5 test tubes Ø 16 mm A00000014	•	•	•	•	•		
	Foam stand for microtiter A00000015	•	•	•	•	•		
	Small rubber supporting plate Ø 50 mm A00000016	•	•	•	•	•	•	
	Rubber supporting plate Ø 94 mm A00000017					•		
	Foam stand for 4 tubes Ø 29 mm A00000019	•	•	•	•	•		
	Foam stand for 5 test-tubes Ø 24 mm A00000389	•	•	•	•	•		
	Mixing cup head 10002021	•	•					
	Mixing cup head 10005195			•	•	•	•	
	Plug USA for power supply 10009118	•	•	•	•	•	•	•
	Plug UK for power supply 10009119	•	•	•	•	•	•	•
	Plug AU for power supply 10009120	•	•	•	•	•	•	•
	Accessory for holding 8 bottles, 1L A00001023							•
	Glass bottle with round glass cap, 2 liter A00001024							•
	Polyethylene bottle, 1 liter A00001022							•

MULTI-TX5

The MULTI-TX5 Digital is the exclusive solution for all the multi-tube mixing tasks, even the most challenging ones. The MULTI-TX5 Digital supports various foam racks for different vortexing tubes being an extremely versatile multi-tube vortex mixer to emulsify, disintegrate, mix, or homogenize samples.

Safe and Programmable

Lock feature to prevent unintentional modifications.
Unattended stirring from 1 minute to 99 h : 59 minutes.

Easy to Use

Easy to operate digital interface with icons. An acoustic signal/sound informs you when the countdown is over.

Simplified Operation

With the MULTI-TX5 Digital you can perform any mixing tasks and then change the foam rack for your next application in just a few simple steps.

- Stirring speed from 100 to 2500 rpm
- Timer & Auto-reverse
- Safety Lock



MULTI-TX5 Digital Vortex

100÷240 V / 50-60 Hz

F202A0460

Accessories - Sample Rack

Various foam racks for vortexing tubes with different dimensions ensure premium versatility in the lab and make the MULTI-TX5 Digital ideal for a wide variety of mixing applications.

Sample Rack for Test Tube Ø 10 mm
44 Positions

Code A00000449



Sample Rack for Test Tube Ø 12 mm
44 Positions

Code A00000450



Sample Rack for Test Tube Ø 13 mm
44 Positions

Code A00000451



Sample Rack for Test Tube Ø 16 mm
44 Positions

Code A00000452



Sample Rack for Test Tube Ø 25 mm
14 Positions

Code A00000453



Sample Rack for Test Tube Ø 29 mm
14 Positions

Code A00000454



Disperser

OV 725 Digital

Premium digital disperser featuring a powerful brushless motor, electronic speed control, integral cyclic timer and advanced safety features. Ideal for homogenization, emulsification, suspensions, and high-speed mixing tasks.

Efficient and Durable

With a versatile range of dispersing tools accommodating volumes from 0.2ml to 2.5L, it ensures optimal performance even with viscous samples up to 5,000 mPas. Its robust construction and powerful brushless motor guarantee durability, minimal maintenance, and efficient heat dissipation.

Precise and Safe

Intuitive LED display and user-friendly control panel for easy and precise speed adjustment. Safety features like soft start-up, temperature monitoring, and tool detection alarms ensure maximum user protection. Enhanced performance and reproducibility are achieved through compatibility with PTFE seals, while LED indicators and maintenance timers streamline timely replacements.

- Volume range (H₂O) from 0,2 to 2500 ml
- Speed range from 2000 to 25000 rpm
- Timer



ERMES ENABLED

Configurations - OV 725 Digital



OV 725



OV 725 Digital System



OV 725 Digital	230 V / 50-60 Hz	F20900475*
OV 725 Digital	115 V / 60 Hz	F20910475*
OV 725 Digital System	230 V / 50-60 Hz	SA20900475**
OV 725 Digital System	115 V / 60 Hz	SA20910475**

*Includes: OV 725 Digital Disperser; Tool disassembly kit.

**Includes: OV 725 Digital Disperser; Tool disassembly kit; Double Rod Mini H-Stand; D20-S20C-P-R20S Dispersing tool.

OV 625 Digital

Powerful digital disperser designed to guarantee precision and high shearing force. The ideal solution for consistent homogenization, emulsification, suspensions, and high-speed mixing of biological tissues, pharmaceuticals, cosmetics and food products.

Accuracy and Ease-of-Use

The bright digital display and the comfortable rotating knob enable precise electronic speed settings and control. The control panel has been designed to optimize the user experience and offer excellent visibility. The stainless-steel dispersing tools can be fixed quickly and easily.

Safe and Resistant

A resistant and robust housing protects the internal electronic parts. Various safety functions, such as a soft start, motor overload protection, and overtemperature alarms, ensure the highest safety in daily operations.

- Volume range (H₂O) from 0,2 to 2500 ml
- Speed range from 2000 to 25000 rpm



Configurations - OV 625 Digital



OV 625 Digital	230 V / 50-60 Hz	F20900470*
OV 625 Digital	115 V / 60 Hz	F20910470*
OV 625 Digital System	230 V / 50-60 Hz	SA20900470**
OV 625 Digital System	115 V / 60 Hz	SA20910470**

*Includes: OV 725 Digital Disperser; Tool disassembly kit.

**Includes: OV 725 Digital Disperser; Tool disassembly kit; Double Rod Mini H-Stand; D20-S20C-P-R20S Dispersing tool.

Accessories - Dispersing Tools

High-quality stainless steel dispersing tools featuring a PTFE seal. Velp D20 series tools ensure high chemical resistance and easy and quick installation procedure.

Included with the system



D20-S20C-P-R20S
Code A00000478

Dispersing tool suitable for the majority of laboratory applications.

- Volume: 50 - 2,000 ml
- Stator diameter: 20 mm
- Rotor diameter: 15 mm
- Ultimate fineness emulsion: 1 - 10 µm
- Ultimate fineness suspension: 10 - 50 µm

Industry:



D20-S20F-P-R20C
Code A00000462

Dispersing tool for solid-liquid dispersion, suitable for fibrous samples.

- Volume: 50 - 2,000 ml
- Stator diameter: 20 mm
- Rotor diameter: 15 mm
- Ultimate fineness emulsion: 1 - 7 µm
- Ultimate fineness suspension: 5 - 40 µm

Industry:



D20-S20F-P-R20E
Code A00000463

Emulsifying tool for liquid-liquid dispersions requiring a high final fineness.

- Volume: 50 - 2,000 ml
- Stator diameter: 20 mm
- Rotor diameter: 15 mm
- Ultimate fineness emulsion: 1 - 7 µm
- Ultimate fineness suspension: 5 - 40 µm

Industry:



D20-S20F-P-R20M
Code A00000464

Dispersing tool, suitable for emulsions (liquid-liquid) and suspensions (solid-liquid), requiring high final fineness.

- Volume: 50 - 2,000 ml
- Stator diameter: 20 mm
- Rotor diameter: 15 mm
- Ultimate fineness emulsion: 1 - 7 µm
- Ultimate fineness suspension: 5 - 40 µm

Industry:



D20-S25C-P-R25C
Code A00000479

Universal dispersing tool for high volumes, particularly suitable for dispersing solid phases.

- Volume: 100 - 2,500 ml
- Stator diameter: 25 mm
- Rotor diameter: 18 mm
- Ultimate fineness emulsion: 1 - 10 µm
- Ultimate fineness suspension: 15 - 50 µm

Industry:



D20-S20F-P-R25E
Code A00000480

High peripheral speed emulsifying tool suitable for particularly fine liquid-liquid dispersions.

- Volume: 100 - 2,500 ml
- Stator diameter: 25 mm
- Rotor diameter: 18 mm
- Ultimate fineness emulsion: 1 - 5 µm
- Ultimate fineness suspension: 5 - 25 µm

Industry:



D20-S25F-P-R25M
Code A00000469

Dispersing tool for particularly fine emulsions (liquid-liquid) and suspensions (solid-liquid).

- Volume: 100 - 2,500 ml
- Stator diameter: 25 mm
- Rotor diameter: 18 mm
- Ultimate fineness emulsion: 1 - 5 µm
- Ultimate fineness suspension: 5 - 25 µm

Industry:



D20-S40C-P-R25C
Code A00000472

Dispersing tool for high-speed stirring and crushing of solid samples.

- Volume: 1,000 - 4,000 ml
- Stator diameter: 40 mm
- Rotor diameter: 18 mm

Industry:



D20-S5S-P-R5S
Code A00000473

Dispersing tool for solid-liquid and liquid-liquid dispersions, suitable for processing particularly small volumes.

- Volume: 0.2 - 50 ml
- Stator diameter: 5 mm
- Rotor diameter: 3.2 mm
- Ultimate fineness emulsion: 1 - 10 µm
- Ultimate fineness suspension: 10 - 50 µm

Industry:

Industry - Legend

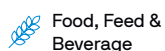

Food, Feed & Beverage



Pharmaceutical & Life Science

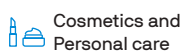

Cosmetics and Personal care



Chemical and Petrochemical

Dry Block Heater & COD

ECODryBlock

ECODryBlock is a modular, digital, and high-precision dry block heater designed to deliver uniform, stable, and controlled temperature conditions across multiple samples. It ensures precise and reproducible heating, making it ideal for sample preparation, incubation, DNA denaturation, enzymatic reactions, culture media tests. In addition, thanks to its extended temperature range up to 165 °C, it can also perform COD analysis.

Flexible and Modular

One ControlPad can manage up to two independent heating Modules, each accommodating two aluminum blocks (95x76x51 mm).

A wide range of interchangeable blocks adapts to any application and vessel, ensuring maximum flexibility for Life Science and Environmental laboratories.

Intuitive and Easy-to-Use

The smart touchscreen interface allows effortless temperature and timer settings, providing complete control over heating conditions and ensuring safe, efficient operation.



Configurations - ECODryBlock



ECODryBlock System	115 V - 230 V	SA101A0700
ECODryBlock System COD 24	115 V - 230 V	SB101A0700
ECODryBlock System COD 4	115 V - 230 V	SC101A0700
ECODryBlock no ControlPad*	115 V - 230 V	F101A0700

*addition to the system

Accessories - Blocks

ECODryBlock offers maximum versatility with a wide range of interchangeable and easy-to-clean aluminum blocks, designed to accommodate vials, microcentrifuge tubes, PCR tubes, PCR strips, Greiner tubes, microplates, and cuvettes.

Blocks for Standard test tubes

Velp code	Description	Suitable for	Well Size (mm)	No. of Wells	Well Depth (mm)
A00000495	STT-W30-D060-A Block	Round bottom tubes (6mm)	Ø 8.3	30	48.4
A00000496	STT-W24-D100-A Block	Round bottom tubes (10mm)	Ø 10.7	24	48.4
A00000497	STT-W16-D130-A Block	Round bottom tubes (12/13 mm)	Ø 13.9	16	48.4
A00000498	STT-W20-D130-A Block	Round bottom tubes (12/13 mm)	Ø 13.9	20	48.4
A00000499	STT-W12-D160-A Block	Round bottom tubes (15/16 mm)	Ø 17.5	12	48.4
A00000500	STT-W12-D180-A Block	Round bottom tubes (17/18 mm)	Ø 19.1	12	48.4
A00000501	STT-W08-D200-A Block	Round bottom tubes (20 mm)	Ø 21	8	48.4
A00000502	STT-W06-D250-A Block	Round bottom tubes (25 mm)	Ø 26.2	6	48.4
A00000503	STT-W04-D350-A Block	Round bottom tubes (35 mm)	Ø 35	4	47.6

Blocks for Vials

Velp code	Description	Suitable for	Well Size (mm)	No. of Wells	Well Depth (mm)
A00000514	VLS-W20-D120-A Block	12 mm vials	Ø 12.7	20	30
A00000515	VLS-W20-D150-A Block	15 mm vials	Ø 15.8	20	35
A00000516	VLS-W15-D160-A Block	16 mm vials	Ø 16.4	15	45
A00000517	VLS-W12-D170-A Block	17 mm vials	Ø 17.8	12	45
A00000518	VLS-W12-D190-A Block	19 mm vials	Ø 19.7	12	45
A00000519	VLS-W09-D210-A Block	21 mm vials	Ø 21.7	9	45
A00000520	VLS-W08-D230-A Block	23 mm vials	Ø 23.8	8	45
A00000521	VLS-W08-D250-A Block	25 mm vials	Ø 25.8	8	45
A00000522	VLS-W06-D280-A Block	28 mm vials	Ø 28.8	6	45

Blocks for Micro Centrifuge Tubes

Velp code	Description	Suitable for	Well Size (mm)	No. of Wells	Well Depth (mm)
A00000504	MCT-W30-V005-A Block	PCR tubes (0.5 ml)	Ø 7.9	30	27.6
A00000505	MCT-W20-V015-A Block	Microcentrifuge tubes (1.5 ml) (Eppendorf™)	Ø 11.5	20	36.9
A00000506	MCT-W20-V015-B Block	Microcentrifuge tubes (1.5 ml)	Ø 10.9	20	39.1
A00000507	MCT-W20-V020-A Block	Microcentrifuge tubes (2.0 ml) (Eppendorf™)	Ø 10.9	20	38.1
A00000508	MCT-W20-V020-B Block	Microcentrifuge tubes (2.0 ml) (Corning™)	Ø 10.9	20	38.1

Blocks for Conical Bottom Centrifuge Tubes

Velp code	Description	Suitable for	Well Size (mm)	No. of Wells	Well Depth (mm)
A00000509	CCT-W12-V150-A Block	Conical centrifuges tube (15 ml)	Ø 17.1	12	44.5
A00000510	CCT-W05-V500-A Block	Conical centrifuges tube (50 ml)	Ø 29	5	47.6

Combination Blocks

Velp code	Description	Suitable for	Well Size (mm)	No. of Wells	Well Depth (mm)
A00000511	STT-W14-COMBO Block	Test tube combination, 6 / 12 / 13 / 25 mm	Ø 8.3 Ø 13.9 Ø 26.2	6 5 3	48.4 48.4 48.4
A00000512	CCT-W09-COMBO Block	Centrifuge tube combination, 1.5 / 15 / 50 ml	Ø 11.1 Ø 17.1 Ø 29	4 3 2	39.1 44.5 47.6
A00000513	MCT-W21-COMBO Block	Microcentrifuge tube combination, 0.5 / 1.5 / 2.0 ml	Ø 7.9 Ø 11.1 Ø 11.5	6 10 5	27.6 39.1 38.1

Blocks for PCR

Velp code	Description	Suitable for	Well Size (mm)	No. of Wells	Well Depth (mm)
A00000523	PCR-W64-V002-A Block	64 x individual PCR tubes (0.2 ml tubes)	Ø 6.4	64	20.2
A00000524	PCR-W80-V002-A Block	10 x 8 individual PCR tube strips (0.2 ml tubes)	Ø 6.6	80	15.5
A00000525	PCR-W96-V002-A Block	1 x 96 - well PCR plate (0.2 ml tubes)	Ø 6.6	96	15.5

Blocks for Cuvette

Velp code	Description	Suitable for	Well Size (mm)	No. of Wells	Well Depth (mm)
A00000526	CUV-W12-D125-A Block	2 x 6 cuvettes (12.5 mm)	-	2	25.4

Blocks for COD

Velp code	Description	Suitable for	Well Size (mm)	No. of Wells	Well Depth (mm)
A00000529	COD-W04-D420-A Block	Round bottom COD test tube (42mm)	Ø 42	4	51
A00000530	COD-W20-COMBO Block	Round bottom COD test tube (16 / 22mm)	Ø 16 Ø 22	18 2	47 45.5
A00000494	COD-W24-D160-A Block	Round bottom COD test tube (16mm)	Ø 16	24	47



BOD Respirometers

RESPIROMETRIC Sensor System 6 BOD

The RESPIROMETRIC Sensor System BOD is designed to be a versatile solution with minimum footprint for aerobic degradation tests for industrial and domestic water quality testing.

- Ideal for: BOD5, BOD7, BOD Ultimate, assessment of disinfection on BOD.
- Biodegradation of monomers application to study the microbial activities involved in the production of plastics.
- Results reading in pressure (millibar) and BOD (mg/l).
- Easy-to-use and powerful sensor with 4 digit LED Display.
- Unique wireless control from your PC and Velp Ermes cloud platform.



ERMES ENABLED

RESPIROMETRIC Sensor System 6
RESPIROMETRIC Sensor System 6

230 V / 50-60 Hz
115 V / 60 Hz

SA10200146
SA10210146

RESPIROMETRIC Sensor System 6 no Databox™
RESPIROMETRIC Sensor System 6 no Databox™

230 V / 50-60 Hz
115 V / 60 Hz

SB10200146
SB10210146

Included in the system: Stirring station, 500 ml amber bottles, KOH containers, stirring bars, DataBox™ and RESPIROSoft™ software.

RESPIROMETRIC Sensor System 6 Maxi BMP

The RESPIROMETRIC Sensor System Maxi BMP is designed to support anaerobic respiration studies to determine the Biochemical Methane Potential (BMP) of biomass. The BMP analysis studies the production of biogas from organic wastes mainly for Waste and Wastewater treatment and for Renewable Energy Production.

- Results reading in pressure (millibar) and automatic conversion in BMP value (NmLCH₄/gSV)
- The system is suitable also for other anaerobic studies such as Denitrification Tests (Requires 6 Denitrification glass bottles (A00000410)).
- Easy-to-use and powerful sensor with 4 digit LED Display.
- Unique wireless control from your PC and Velp Ermes cloud platform.
- Wireless DataBox™ e RESPIROSoft™



ERMES ENABLED

RESPIROMETRIC Sensor System 6 Maxi
RESPIROMETRIC Sensor System 6 Maxi

230 V / 50-60 Hz
115 V / 60 Hz

SA10200156
SA10210156

RESPIROMETRIC Sensor System 6 Maxi no Databox™
RESPIROMETRIC Sensor System 6 Maxi no Databox™

230 V / 50-60 Hz
115 V / 60 Hz

SB10200156
SB10210156

Included in the system: Maxi stirring station, 1000 ml bottles, KOH containers, stirring bars, DataBox™ and RESPIROSoft™ software.

RESPIROMETRIC Sensor System 6 for Soils Analysis

The RESPIROMETRIC Sensor System for soil analysis is designed to support aerobic degradation tests on soil and compost. The analysis provides microbial soil respiration results from the mineralization of organic substances. A major application of these test is related to the detection and monitoring processes during decontaminations and clean-ups.

- The analysis is carried out directly on soil/compost in the 1000ml flask.
- Results reading in Pressure values (millibar).
- Easy-to-use and powerful sensor with 4 digit LED Display.
- Unique wireless control from your PC and Velp Ermes cloud platform.
- Wireless DataBox™ e RESPIROSoft™



3 YEARS WARRANTY

ERMES ENABLED

RESPIROMETRIC Sensor System for Soil Analysis

-

SA102B0176

RESPIROMETRIC Sensor System for Soil Analysis no Databox™

-

SB102B0176

Included in the system: 6 Kits soil analysis, DataBox™ and RESPIROSoft™ software.

RESPIROMETRIC Sensor System 6 for Plastic

The RESPIROMETRIC Sensor System for plastic biodegradability is designed to support aerobic degradation test for the determination of the degree of aerobic biodegradability of plastic materials, including those containing formulation additives, in an aqueous medium.

- Multistirrer Digital 6-positions to precisely set stirring speed and enable the lock feature to avoid unintentional modification of the stirring speed.
- Results reading in Pressure values (millibar).
- Easy-to-use and powerful sensor with 4 digit LED Display.
- Unique wireless control from your PC and Velp Ermes cloud platform.
- Wireless DataBox™ e RESPIROSoft™



3 YEARS WARRANTY

ERMES ENABLED

RESPIROMETRIC Sensor System for Plastic Biodegradability

100-240 V / 50-60Hz

SA102A0166

RESPIROMETRIC Sensor System per for Plastic Biodegradability no Databox™

100-240 V / 50-60Hz

SB102A0166

Included in the system: Multistirrer Digital 6-positions, 6 Kits plastic biodegradability analysis, stirring bars, DataBox™ and RESPIROSoft™ software.

BOD Sensor

Innovative, mercury-free and extremely reliable solution for BOD analysis. The BOD sensors include KOH traps.

Precise and Easy to Use

It can measure on scales of 90, 250, 600, 999 and 4000 ppm BOD..

Safe

The IP 54 Protection Rating guarantee durability even in the most aggressive environments. Class 3 IEC 1010 conformity.

Compact Design

BOD System 6 is designed to optimize space consumption inside cooled incubators.



BOD Sensor	-	F102B0133
BOD Sensor Set	-	F102B0134

BOD Sensor System 6

Innovative, mercury-free and extremely reliable solution for BOD analysis.

The 6 position systems include the BOD sensors, stirring station, stirring bars and KOH traps.

Precise and Easy to Use

It can measure on scales of 90, 250, 600, 999 and 4000 ppm BOD.

Safe

The IP 54 Protection Rating guarantee durability even in the most aggressive environments. Class 3 IEC 1010 conformity.

Compact Design

BOD Sensor System 6 is designed to optimize space consumption inside cooled incubators.

- BOD Scales 90, 250, 600, 999, 4000 ppm



BOD Sensor System 6	230 V / 50-60 Hz	SA10200136
BOD Sensor System 6	115 V / 60 Hz	SA10210136

Included in the system: Stirring station 6 positions, BOD Sensor, 500 ml amber bottles, KOH containers, stirring bars.

BOD Sensor System 10

Innovative, mercury-free and extremely reliable solution for BOD analysis. The 10 position systems include the BOD sensors, stirring station, stirring bars and KOH traps.

Precise and Convenient

It can measure on scales of 90, 250, 600, 999 and 4000 ppm BOD.

Compact Design

BOD Sensor System 10 is designed to optimize space consumption inside cooled incubators.

- BOD Scales 90, 250, 600, 999, 4000 ppm



BOD Sensor System 10

230 V / 50-60 Hz

SA10200137

BOD Sensor System 10

115 V / 60 Hz

SA10210137

Included in the system: Stirring station 10 positions, BOD Sensor, 500 ml amber bottles, KOH containers, stirring bars.

Accessories - BOD and Respirometers

	RESPIROMETRIC Sensor System 6 BOD	RESPIROMETRIC Sensor System 6 Maxi BMP	RESPIROMETRIC Sensor System 6 for Soil Analysis	RESPIROMETRIC Sensor System 6 for Plastic Biodegradability	BOD Sensor System
A00000135 Sensor Check	•	•	•	•	•
A00000136 Pastiglie per Test Controllo, 10 pcs/box	•	•	•	•	•
A00000221 Cavo alimentazione multiplo EU	•	•		•	•
A00000222 Cavo alimentazione multiplo UK	•	•		•	•
A00000223 Cavo alimentazione multiplo AU	•	•		•	•
10003083 Spina USA per alimentatore	•	•		•	•
10003084 Spina UK per alimentatore	•	•		•	•
10003085 Spina AU per alimentatore	•	•		•	•
A00000410 Bottiglia per denitrificazione		•			
E00010012 Velp Ermes 1 anno connessione	•	•	•	•	
E00010036 Velp Ermes 3 anni connessione	•	•	•	•	

Cooled Incubators

FOC 200IL Connect

FOC 200IL Connect is the cloud-enabled illuminated cooled incubator ideal for plant growth, seed germination, cultivation, breeding of plants, insects and small animals, bacteria culturing, fermentation studies.

Convenient and Efficient

FOC 200IL Connect is equipped with 2 lighted shelves and an internal transparent door.

Efficient Thermoregulation

FOC 200IL Connect guarantees a perfect thermoregulation and stability thanks to the Auto-Tuning system. The use of forced ventilation uniforms the internal temperature.

Exclusive Connectivity

Premium Wi-Fi connectivity to Velp Ermes Cloud Platform. TEMPSoft™ software with 485 cable connection to constant monitor the instrument. MODBUS communications for PLC connection.

- Total volume 169 L
- Temperature from 3 to 50 °C
- Auto-Tuning Technology $\pm 0.5^{\circ}\text{C}$
- Timer Lighting Cycles
- Internal Transparent Door



ILLUMINATED

FOC 200IL Connect

* The cooled incubator is supplied with 2 shelves 40002722 and 1 shelf 10008039



(not available in USA, Mexico and Canada)

ERMES ENABLED

230 V / 50-60 Hz

F10400544*

FOC 200I Connect

FOC 200I Connect is the cloud-enabled cooled incubator with internal transparent door ensuring excellent temperature stability and homogeneity.

Convenient and Efficient

FOC 200I Connect is equipped with an internal transparent door allowing sample monitoring with no temperature alteration.

Efficient Thermoregulation

FOC 200I Connect guarantees a perfect thermoregulation and stability thanks to the Auto-Tuning system. The use of forced ventilation uniforms the internal temperature.

Exclusive Connectivity

Premium Wi-Fi connectivity to Velp Ermes Cloud Platform. TEMPSoft™ software with 485 cable connection to constant monitor the instrument. MODBUS communications for PLC connection.

- Total volume 169 L
- Temperature from 3 to 50 °C
- Auto-Tuning Technology $\pm 0.5^{\circ}\text{C}$
- Internal Transparent Door



FOC 200I Connect

* The cooled incubator is supplied with 3 shelves 10008039



(not available in USA, Mexico and Canada)

ERMES ENABLED

230 V / 50-60 Hz

F10400543*

FOC 200E Connect

FOC 200E Connect is the cloud-enabled cooled incubator ensuring excellent temperature stability and homogeneity.

Convenient and Efficient

FOC 200E Connect is asy to use thanks to the intuitive digital interface.

Efficient Thermoregulation

FOC 200E Connect guarantees a perfect thermoregulation and stability thanks to the Auto-Tuning system. The use of forced ventilation uniforms the internal temperature.

Exclusive Connectivity

Premium Wi-Fi connectivity to Velp Ermes Cloud Platform. TEMPSoft™ software with 485 cable connection to constant monitor the instrument. MODBUS communications for PLC connection.

- Total volume 169 L
- Temperature from 3 to 50 °C
- Auto-Tuning Technology $\pm 0.5^{\circ}\text{C}$



FOC 200E Connect

* The cooled incubator is supplied with 3 shelves 10008039



(not available in USA, Mexico and Canada)

ERMES ENABLED

230 V / 50-60 Hz

F10300542*

FOC 120I Connect

FOC 120I Connect is the cloud-enabled cooled incubator with internal transparent door ensuring excellent temperature stability and homogeneity.

Convenient and Efficient

FOC 120I Connect is equipped with an internal transparent door allowing sample monitoring with no temperature alteration.

Efficient Thermoregulation

FOC 120I Connect guarantees a perfect thermoregulation and stability thanks to the Auto-Tuning system. The use of forced ventilation uniforms the internal temperature.

Exclusive Connectivity

Premium Wi-Fi connectivity to Velp Ermes Cloud Platform. TEMPSoft™ software with 485 cable connection to constant monitor the instrument. MODBUS communications for PLC connection.

- Total volume 109 L
- Temperature from 3 to 50 °C
- Auto-Tuning Technology $\pm 0.5^{\circ}\text{C}$



FOC 120I Connect

* The cooled incubator is supplied with 3 shelves 10008039



(not available in USA, Mexico and Canada)

ERMES ENABLED

230 V / 50-60 Hz

F10400541

FOC 120E Connect

FOC 120E Connect is the cloud-enabled cooled incubator ensuring excellent temperature stability and homogeneity.

Convenient and Efficient

FOC 120E Connect is easy to use thanks to the intuitive digital interface.

Efficient Thermoregulation

FOC 120E Connect guarantees a perfect thermoregulation and stability thanks to the Auto-Tuning system. The use of forced ventilation uniforms the internal temperature.

Exclusive Connectivity

Premium Wi-Fi connectivity to Velp Ermes Cloud Platform. TEMPSoft™ software with 485 cable connection to constant monitor the instrument. MODBUS communications for PLC connection.

- Total volume 109 L
- Temperature from 3 to 50 °C
- Auto-Tuning Technology $\pm 0.5^{\circ}\text{C}$



FOC 120E Connect

* The cooled incubator is supplied with 2 shelves



(not available in USA, Mexico and Canada)

ERMES ENABLED

230 V / 50-60 Hz

F10300540

FTC 120

Compact and efficient incubator specially designed for BOD respirometric measurement ensuring a constant 20°C temperature. FTC 120 is equipped with 2 internal sockets.

Efficient Thermoregulation

The use of forced ventilation uniforms the internal temperature.

- Total volume 109 L
- Constant temperature 20 °C



FTC 120

* The cooled incubator is supplied with 2 shelves



(not available in USA, Mexico and Canada)

230 V / 50-60 Hz

F10300305

Accessories - Cooled Incubators

	FOC 200IL Connect	FOC 200I Connect	FOC 200E Connect	FOC 120I Connect	FOC 120E Connect	FTC 120
A00000404 TEMPSoft with RS485 cable	•	•	•	•	•	
A00000405 Interconnection cable FOC Connect	•	•	•	•	•	
A00000406 IQ/OQ FOC Connect and FTC 120 Manual	•	•	•	•	•	•
A00000221 Multi-socket extension cable EU	•	•	•	•	•	•
A00000222 Multi-socket extension cable UK	•	•	•	•	•	•
A00000223 Multi-socket extension cable AU	•	•	•	•	•	•
10008039 Shelf for FOC 200, FOC 120, FTC 120	•	•	•	•	•	•
10008040 Bottom Shelf FOC 120, FTC 120				•	•	•
40002722 Lighted shelf for FOC 200 IL	•					
E00010012 Velp Ermes 1 year Connection	•	•	•	•	•	
E00010036 Velp Ermes 3 year Connection	•	•	•	•	•	



Flocculators

JLT 6

Digital flocculator featuring adjustable stirring speed and timer, a powerful brushless motor, and an illuminated back panel. JLT 6 provides standard and repeatable conditions for testing 6 samples with the same speed and time settings.

Reliable

JLT 6 guarantees a precise speed thanks to the electronically controlled brushless motor. It also ensures a strong resistance to chemical and mechanical corrosion.

Practical

JLT 6 has an illuminated back panel that simplifies the observation of the samples. All the stirring rods are adjustable in height without tools.

- Stirring speed from 10 to 300 rpm
- Digital
- Programmable speed and time



JLT 6



100-240 V / 50-60 Hz

F105A0109

JLT 4

Digital flocculator featuring adjustable stirring speed and timer, a powerful brushless motor, and an illuminated back panel. JLT 4 provides standard and repeatable conditions for testing 4 samples with the same speed and time settings.

Reliable

JLT 4 guarantees a precise speed thanks to the electronically controlled brushless motor. It also ensures a strong resistance to chemical and mechanical corrosion.

Practical

JLT 4 has an illuminated back panel that simplifies the observation of the samples. All the stirring rods are adjustable in height without tools.

- Stirring speed from 10 to 300 rpm
- Digital
- Programmable speed and time



JLT 4



100-240 V / 50-60 Hz

F105A0108

FC6S

Analog flocculator with adjustable stirring speeds, a powerful brushless motor, and an illuminated back panel. With 6 independent positions, FC6S allows for testing and simulating different conditions simultaneously, ideal for the optimization of water treatment processes.

Reliable

FC6S guarantees a precise speed thanks to the electronically controlled brushless motor. It also ensures a strong resistance to chemical and mechanical corrosion.

Versatile

With the FC6S, the same product can be submitted to different conditions in parallel, while the speed can be changed during the test.

- Stirring speed 10 - 15 - 30 - 45 - 60 - 90 120 - 150 - 200 - 300 rpm
- Independent selectable speed for each position



FC6S

100-240 V / 50-60 Hz

F105A0112

FC4S

Analog flocculator with adjustable stirring speeds, a powerful brushless motor, and an illuminated back panel. With 4 independent positions, FC4S allows for testing and simulating different conditions simultaneously, ideal for the optimization of water treatment processes.

Reliable

FC4S guarantees a precise speed thanks to the electronically controlled brushless motor. It also ensures a strong resistance to chemical and mechanical corrosion.

Versatile

With the FC4S, the same product can be submitted to different conditions in parallel, while the speed can be changed during the test.

- Stirring speed 10 - 15 - 30 - 45 - 60 - 90 120 - 150 - 200 - 300 rpm
- Independent selectable speed for each position



FC4S

100-240 V / 50-60 Hz

F105A0111

FP4

Digital portable flocculator featuring adjustable stirring speed and timer, a powerful brushless motor, a central lighting system, and a practical handle for comfortable and reliable on-site water treatment tests. FP4 can be connected to a battery or a car cigarette lighter (12V).

Reliable

FP4 guarantees a precise speed thanks to the electronically controlled brushless motor. It also ensures a strong resistance to chemical and mechanical corrosion.

Practical

FP4 is designed to be used on-site for immediate results. FP4 provides standard and repeatable conditions for testing 4 samples with the same speed and time settings.

- Stirring speed 10 to 300 rpm
- Digital and portable
- Programmable speed and time



FP 4

100-240 V / 50-60 Hz

F105A0117

Accessories - Flocculators

	JLT 6	JLT 4	FC6S	FC4S	FP4
A00001000 Plastic beaker 1000 ml	•	•	•	•	•
A00001001 Glass beaker 1000 ml	•	•	•	•	•
A00001002 Transparent plastic Imhoff cone	•	•	•	•	
A00001003 Glass graduated Imhoff cone	•	•	•	•	
A00001004 Stand for 2 Imhoff cones	•	•	•	•	
A00001005 Stand for 2 Imhoff cones					•
A00000319 IQ/OQ Manual JLT	•	•			
A00000379 IQ/OQ FC4S - FC6S Manual			•	•	
10003722 Power supply cord, US plug	•	•	•	•	
10003723 Power supply cord, UK plug	•	•	•	•	
10003724 Power supply cord, AU plug	•	•	•	•	
10003083 Plug USA for power supply					•
10003084 Plug UK for power supply					•
10003085 Plug AU for power supply					•

Other Solutions

OCB Open Circulating Baths

Efficient and precise open circulating bath that ensures excellent temperature homogeneity ($\pm 1^\circ\text{C}$), accurate control and thermostating of testing materials.

Easy to Use

LCD display ensures a precise temperature setting. A wide choice of test tube racks is available.

- Temperature from room temperature to 105 °C



(not available in USA, Mexico and Canada)

3 YEARS WARRANTY

OCB

230 V / 50-60 Hz

F40300240

OCB

115 V / 50-60 Hz

F40310240

For accessories visit online www.Velp.com

SP 311 Peristaltic Pumps

An easy to use and reliable peristaltic pump, ideal for transferring gas, liquids, mixtures and emulsions in various industries.

Easy to Use and Reliable

Tubing resists most chemicals and ensures minimum maintenance.

The electronic speed control makes simple the control of the instrument.



(not available in USA, Mexico and Canada)

3 YEARS WARRANTY

SP 311/2

230 V / 50-60 Hz

F40200002

SP 311/6

230 V / 50-60 Hz

F40200006

SP 311/12

230 V / 50-60 Hz

F40200012

SP 311/60

230 V / 50-60 Hz

F40200060

TB1 Turbidimeter

Waterproof, precise and easy to calibrate portable turbidimeter that measures the turbidity of aqueous samples simply and accurately with nephelometric method.

Reliable and Precise

Tb1 is supplied with 4 calibration standards (800, 100, 20 and 0.02 NTU) and can test up to 1200 samples with one set of batteries.

Resistant

IP 67 protection against ingress of particles and water.



(not available in USA, Mexico and Canada)

3 YEARS WARRANTY

TB 1

For accessories visit online www.Velp.com

R109B12150

Headquarters

Velp Scientifica Srl
Via Stazione 16
20865 Usmate (MB)
Italy
Tel. +39 039 628811
Velpitalia@Velp.com

USA

Velp Scientifica Inc
40, Burt Drive, Unit #1,
Deer Park
NY 11729 - U.S.
Tel. +1 631 573 6002
Velpusa@Velp.com

China

Velp China
Room 828, Building 1,
No.778, Jinji Road
Pudong District,
Shanghai 200000
Tel. 400-089-8029
Velpchina@Velp.com

India

Velpindia@Velp.com

Latam

Velplatam@Velp.com

SEA & Pacific

Velpsea@Velp.com

We reserve the right to make technical alterations
We do not assume liability for errors in printing, typing or transmission

Velp Official Partner

Driven by curiosity



Rev 4.10.2025